

SZ7G/SZ7GE/SZ7GS/SZ7GES series Teach Panel Installation Instruction



Kinco Electric (Shenzhen) Ltd.



Tel: 0755-26585555

Web: www.kinco.cn Email: sales@kinco.cn

Add: Building 1, No. 6 Langshan 1st Rd, Hi-tech Park

North, Nanshan, Shenzhen, China.

1. Installation Note

1.1 Environmental Requirement

Operating temperature: SZ7G /SZ7GE Series HMI can work stably in most industrial environments that the temperature between 32°F to 122°F (0~50°C).
NEMA rating: This Series HMI is NEMA 1 rated in front panel.

Please do not use in the following places:

- Places direct in sunlight
- Surrounding temperature and humidity beyond the specifications
- Places of temperature changes sharply and easily cause condensation
- Places that exist corrosive gas and combustible gas
- Places of much dust, dirt, salt and iron powder
- Places that will be splashed water, oil and drugs
- Places that bring direct vibration and shock to host

Please take shielding measures in the following places:

- Places that exist electrostatic or other kinds of noise
- Places of strong electromagnetic
- Places that may be exposed to rays
- Places near the power

1.2 Power Requirement

- Input voltage:DC16V~DC32V.
- Particularly note that there must be enough distance between this product and converters or switch power supply. Make sure that the input and output cables of that kind equipment are shield cable and the shielding network is connected with the ground.
- Make sure that the DC power and AC power is isolated.
- Do not use same power supply with the input circuit of inductance load or the controller.

2. Installation Description

2.1 Dimensional Drawing

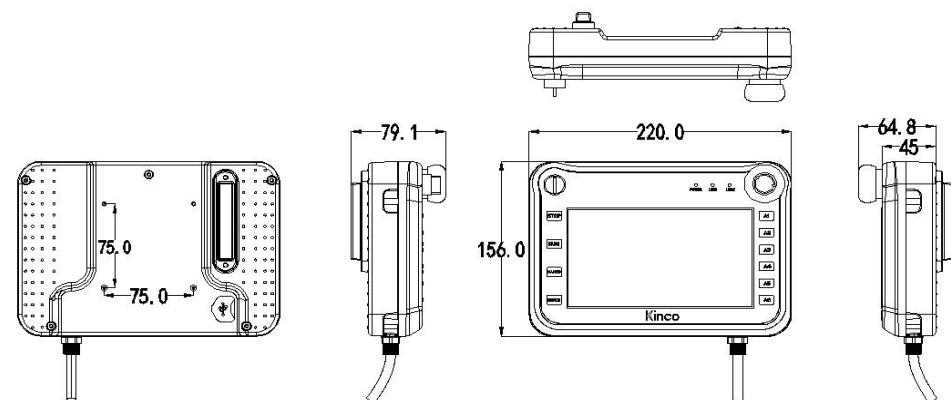

2.2 Installation Instructions

2.2.1 Rack Mounting

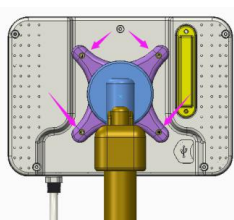

On the back of the product, 4 M4 75*75mm thread holes are reserved, and the hole position of the bracket (refer to the left) is aligned with the thread hole, and the screw is screwed into the M4 specification.

2.2.2 Hanging Mounting

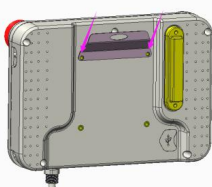

Through sketch left hanging structure, specifications of the screws fixed in the shell reserved above two holes, can suspended in a desired position control.

NOTE: There are only M4 installation screws in the packaging carton. The rack and the sheet metal pendant are just schematic diagrams, needed to customize by customers.

3. Communication connections

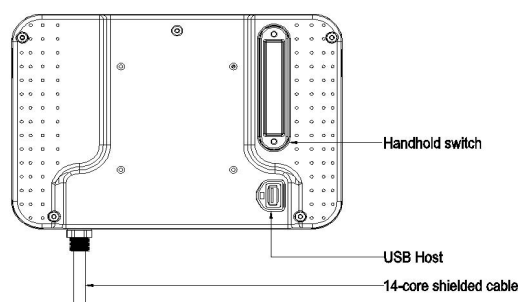

Function	RS485	RS232	Ethernet	USB HOST	Stop all the way	Three choice Switch	Grip switch
SZ7G	✓	✓		✓	✓	✓	
SZ7GE			✓	✓	✓	✓	
SZ7GS	✓	✓		✓	✓	✓	✓
SZ7GES			✓	✓	✓	✓	✓

Note: 1.Note: 1. RS485, RS232 and Ethernet ports are integrated in 14 core shielded cable. See cable signal description below for details.

3.1 RS232 (COM2) serial port

RS232 port for SZ7G / SZ7GS series programming and debugging

Connection	Black/yellow/pink in the 14-core shielded cable(see below)
Port Function	The port is used to upload/ download user configuration program to the HMI to set HMI system parameters and to communication.

3.2 USB HOST

Connection	Connect with USB interface devices or U disks
Port Function	This interface can be connected with USB keyboard, mouse and printers, and the U disk can be used for user's configuration uploading/ downloading as well as data storage.

3.3 RS485 (COM0) serial port (SZ7G & SZ7GS Support)

Connection	Grey/red in the 14-core shielded cable(see below)
Port Function	This port is used to connect the controller with RS-485port.

Note: When you create a project in Kinco HMIware SZ7 and SZ7S share a component icon.

3.4 Ethernet (SZ7GE & SZ7GES Support)

Ethernet interface can adaptive 10 M/ 100 M.

Connection	Grey/red/black/yellow in the 14-core shielded cable (see below)
Port Function	The port can be used for uploading/downloading HMI program, setting system parameters and online simulation. It can connect multiple HMIs via the Ethernet; it can communicate HMI and PLC via the Ethernet, as well as communicate with a PC via the Ethernet port.

4. Operation Mode

4.1 Instructions for entering Operation Mode selection window

Hold pressing on the touch panel when you power on HMI, then HMI will enter operation mode selection window, select the operation mode according to your application. If there is not any operation in 20 seconds after entering operation mode selection window, HMI will enter application (normal working) mode automatically.

4.2 Descriptions of functions in Operation Mode selection window

After entering operation mode selection window, it will pop up a menu. Follows are the descriptions of the functions in the menu:

System Setup: Press this button to enter system setup window. This window is used to set initial window, screen saver time, buzzer and brightness adjustment. After setting, press Restart button to restart HMI.

Firmware Update: Press this button to enter firmware update mode. This window is used to update firmware. Normally this mode is not advised to use without guiding by manufacturer.

Touch Calibration : Press this button to enter touch calibration window. It will restart HMI automatically after calibration successful. There is a timer in this button, it will enter application window if there is no operation within 20s.

Stop timer: Press this button to stop the 20s timer.

Note: There is a multi-languages button; it is used to switch English and Chinese.

5. Detailed description of the 14-core shielded cable

5.1 Detailed description of the 14-core shielded cable

In order to facilitate the use of customers and improve the stability of the products, this series of products adopt 14 core shielded cable, which is twisted in two pairs .

The standard length of cable is 5 meters.

Cable colour	Supply power	COM0: RS485	Ethernet	COM2:RS232	Handhold switch	Emergency switch	3-position selection switch
blue	24V						
orange	0V						
green					Gripping ground		
brown						Emergency stop	
grey		RS485 B	RX_N				
red		RS485 A	RX_P				
blank			TX_N	RS232 Rx			
yellow			TX_P	RS232 Tx			
pink				Signal ground			
purple							Three choice Switch ground
white					Handhold signal		
Blue-red						Emergency signal	
Orange-white							AUTO-signal
Green-white							Remote signal

Note: 1.Emergency stop switch: the switch is in the off state when it is pressed down, and the switch is in the closed state when it is bounced up.

2.The holding switch is divided into two states according to the strength of pressing the switch, namely, light pressing (less strength), heavy case (greater strength), the original state is normally open, light holding signal and holding ground are closed on time, and then heavy holding signal and holding ground are disconnected on time.

5.2 UTP Cable Socket Module Instruction

SZ7GE have Ethernet interface, the wire connection is in accordance with the T568B standard, as follows:

- 1--yellow
- 2--black
- 3--red
- 6--grey

Pin 1, 2, 3, 6 are the pin number on the UTP Cable Socket Module, the color above is the wire color in 14-core shielded cable.

6. After-sales Service

For < Service Terms and Conditions for HMI >, please check :<http://www.kinco.cn>