

Kinco

Let the Chinese manufacturing become the world's top manufacturing

K6S series, compact modular PLC

user's manual

Version revision record

Revised date	Release version	Change the content
2023/12/19	K6S_usermanual_V000	First edition revision

Manual acquisition

This manual is not shipped with the product. If you need to obtain the electronic PDF file, you can log in to the official website of Buke (<https://www.kinco.cn/>), "Service data download", search for keyword download.

Product programming software acquisition

- This product uses KincoBuilder programming software (in accordance with IEC61131-3 standard) for programming debugging, supporting LD and IL languages. The software installation package can be obtained through the corresponding page of the official website (<https://www.kinco.cn/download/plczzz18.html>) 。
- The K6S series requires programming development using the software version of KincoBuilder V8.5.0.3 or newer.
- KincoBuilder Software version downward compatible, the latest version of the software is always compatible with the previous version of the function, new instructions and functions need to use the latest software version and firmware version, in order to ensure the use of experience, please pay attention to and timely download the latest version of the programming software.

safety instruction



This chapter describes the safety precautions needed for the proper use of this product. Before using this product, please read the product manual and the associated manual introduced in the manual to correctly understand the relevant information of safety precautions. Failure to follow the items specified in the safety precautions may result in death, serious injury, or equipment damage.

The "Hazard", "Warning" and "attention" items in the manual do not represent all safety matters to be observed and are only complementary to all safety precautions.

The product shall be used in the environment that meets the requirements of the design specifications, otherwise it may cause failure, and the functional abnormality or component damage caused by failure to comply the relevant regulations are not within the scope of product quality assurance.

Buke will not bear any legal liability for the personal safety accidents and property losses caused by the failure of this manual, the illegal operation of the products.

For the safe use of the product, this manual identifies the precautions with the following signs and graphic symbols, and identifies the important contents related to safety in the precautions shown here, please comply.

	Serious / prohibited No behavior, if not take appropriate careful measures, will lead to serious personal injury and even death.
	warn Warning behavior, if not careful, can lead to serious personal injury and even death.
	pay attention to Indicates general information or indicating behavior, and unexpected results may occur without attention to the corresponding cue.

When the power is powered



- ❖ During the power supply, do not touch any terminal, terminal blocks, do not try to remove any unit. Especially during the power supply or just after the power supply is turned off, the capacitor discharge takes time, which may lead to electric shock or other personal and equipment hazards.

When installing



- ❖ The installation, wiring, maintenance and inspection of this product shall be carried out by professional maintenance personnel with relevant training in electrical equipment and sufficient electrical knowledge.
- ❖ Do not use programmable controllers in the following places: dust, lampblack, conductive dust, corrosive gas, combustible gas; exposed to high temperature, dew, wind and rain; vibration and impact.

Electric shock, fire, and misoperation may also lead to product damage.



- ❖ During screw hole processing and wiring, attention should be paid not to make metal chips, dust and wire head fall into the ventilation hole of the controller, which may cause fire, failure, and other misoperation.

When wiring



- ❖ The installation, wiring, maintenance and inspection of this product must be carried out by the professional electrical maintenance personnel with relevant electrical equipment training and sufficient electrical knowledge.

- ❖ During the wiring operation, it must be done while ensuring that the external power supply of the system is completely disconnected. Otherwise, it is possible to send electric shock or equipment failure, equipment misoperation and other dangers.



- ❖ After the installation and wiring operation, before the power-up and operation, please ensure that the product is fully installed (including the end cover of the product, Plate cover, etc.), otherwise there will be an electric shock danger.
- ❖ Cable terminals shall be well insulated to ensure that the insulation distance between cables will not be reduced after the cables are installed on the terminal table. otherwise Can cause electric shock, short circuit, or equipment damage.



- ❖ During screw hole processing and wiring, attention should be paid not to make metal chips, dust and wire head fall into the ventilation hole of the controller, which may cause fire, failure, and other misoperation.
- ❖ The connected interface type shall be confirmed before the relevant cables are connected. If the type of interface connection is incorrect or the wiring is wrong, it may cause the controller, external equipment failure or damage.
- ❖ The bolts on the terminal row shall be fastened within the specified torque range. Failure to tighten the terminal bolts may cause short circuit, disconnection, fire and other hazards. Excessive fastening of bolts may damage bolts and controllers, resulting in falling parts, short circuit,

fire and other hazards;

- ❖ When using connector and external equipment, pressing, compaction or proper welding shall be performed with the tools specified by the manufacturer. If the connection is bad, it may lead to short circuit, fire or other misoperation.
- ❖ Do not tie the control line and communication cable with the main circuit or power supply line together, or make it too close to each other. Arrange the control line and communication cable and the main circuit power line in the line slot or space more than 100mm apart, otherwise it may cause misoperation due to noise.
- ❖ For applications with severe interference, the input or output cable of the high frequency signal should choose a special shielded cable to improve the anti-interference ability of the system.

System design



- ❖ Please design a safety circuit to ensure the safety of the control system when the external power supply fails or the controller fails.
- ❖ If the output circuit exceeds the rated load current or load short circuit and causes a long overcurrent, the controller may smoke or catch fire, the safety blocking device such as fuse or circuit breaker should be installed externally.



- ❖ Always set the emergency brake circuit, protection circuit, interlock circuit for forward and reverse operation, and position upper and lower limit interlock switch to prevent machine damage in the external circuit of the controller.
- ❖ To ensure the safe operation of the equipment, please design the external protection circuit and safety mechanism.
- ❖ When the CPU of the controller detects all output signals; when the circuit of the controller fails, the output may be uncontrolled. In order to ensure the normal operation of the equipment, appropriate external control circuit should be designed.
- ❖ When the transistor output unit of the controller is damaged, its output status may be uncontrollable.
- ❖ The programmable controller is designed to be applied to indoor electrical environment with overvoltage level II. The power supply system level should have lightning protection device to ensure that the lightning overvoltage is not applied to the power input or signal input and control output ports of the programmable controller, so as to avoid damage to the equipment.

Operation and maintenance



- ❖ The installation, wiring, maintenance and inspection of this product must be conducted by professional electrical maintenance personnel with relevant electrical equipment training and sufficient electrical knowledge.
- ❖ Before cleaning and refastening the bolts and connector installation bolts on the terminal row, make sure that the system power supply is completely cut off.



- ❖ During equipment debugging, read the user manual before online modification, forced output, start (RUN), stop (STOP) and other operations, and then conduct relevant operations after fully confirming its safety.

catalogue

Version revision record	I
Manual acquisition	I
Product programming software acquisition	I
safety instruction	II
1 General instructions	1
1.1 Product Introduction	1
1.2 Product naming and labeling	2
1.2.1 Product Naming Rules	2
1.2.2 Label information	3
1.3 Working and storage conditions	4
1.4 Product list	6
2. Product overview and hardware description	7
2.1 Introduction of K 6 S series	7
2.2 CPU module components and specifications	9
2.2.1 Function Description of the components	9
2.3 Functional description of expanded module components	21
3 Technical parameters	22
3.1 CPU K615S-16DT	22
3.2 Extended expansion module	25
3.2.1 K621S-16DX	25
3.2.2 K622S-16DR	25
3.2.3 K622S-16DT	26
3.2.4 K623S-16DT	27
3.2.5 K622S-16DTN	28
3.2.6 K633S-06IV	29
3.2.7 K631S-04TC	31
3.2.8 K631S-04RD	33
4 Wiring and dimensions	35
4.1 Wiring instructions	35
4.1.1 K615S-16DT	35
4.1.2 K621S-16DX	41
4.1.3 K622S-16DR	42
4.1.4 K622S-16DT	43

The K6S Series user manual

4.1.5 K623S-16DT	44
4.1.6 K622S-16DTN	45
4.1.7 K633S-06IV	46
4.1.8 K631S-04TC	48
4.1.9 K631S-04RD	48
4.2 Wiring list	50
4.2.1 K615S-16DT	50
4.2.2 K621S-16DX	51
4.2.3 K622S-16DR	52
4.2.4 K622S-16DT	53
4.2.5 K623S-16DT	54
4.2.6 K622S-16DTN	55
4.2.7 K633S-06IV	56
4.2.8 K631S-04TC	57
4.2.9 K631S-04RD	58
4.3 Dimension description	59
4.3.1 The CPU module	59
4.3.2 Extended expansion module	60
5 Installation criteria	61
5.1 CPU module connection extension mode	61
5.2 Install with the DIN guide rail	62
5.2.1 The DIN guide rail standard	62
5.2.2 Installation / removal steps of the guide rail	63
5.3 Installation space requirements	65
6 Use entry	67
6.1 Introduction to the KincoBuilder software interface	67
6.2 KincoBuilder new construction project	68
6.3 KincoBuilder hardware configuration	69
6.3.1 KincoBuilder Configure the CPU	69
6.3.1 KincoBuilder Configure the extension module	72
6.4 Simple description of programming	74
6.4.1 Online help	74
6.4.2 KincoBuilder Programming language	75
6.4.3 Programming instructions	76
6.5 Compilation and simulation	77

The K6S Series user manual

6.5.1 Compilation	77
6.5.2 Simulation	78
6.6 Connect and program on / download	81
6.6.1 PC to communicate with K615S-16DT	81
6.6.2 Program Upload / download	85
6.7 Error information and processing	88
6.7.1 KincoBuilder Error message	88
6.7.2 Common Error Information	89
6.8 Firmware update	90
7. Product and service support	93
7.1 Product Support	93
7.2 Contact us	93
8 Appendix	94
8.1 Quick selection list	94

1 General instructions

1.1 Product profile

Kinco-K6S series PLC is a compact modular PLC launched by The Company. The modular connection design saves the horizontal installation space by more than 50%, and can avoid tool fastening wiring, making the installation and maintenance process more simple and efficient."Streamline" design with strong kernel, makes the instruction processing faster, at the same time integrated the high speed input / output, ethernet, CAN, RS485 conventional functions such as interface, further enhance the step PLC in flexibility, reliability, efficient control performance index, provides reliable control solutions for industrial automation system.

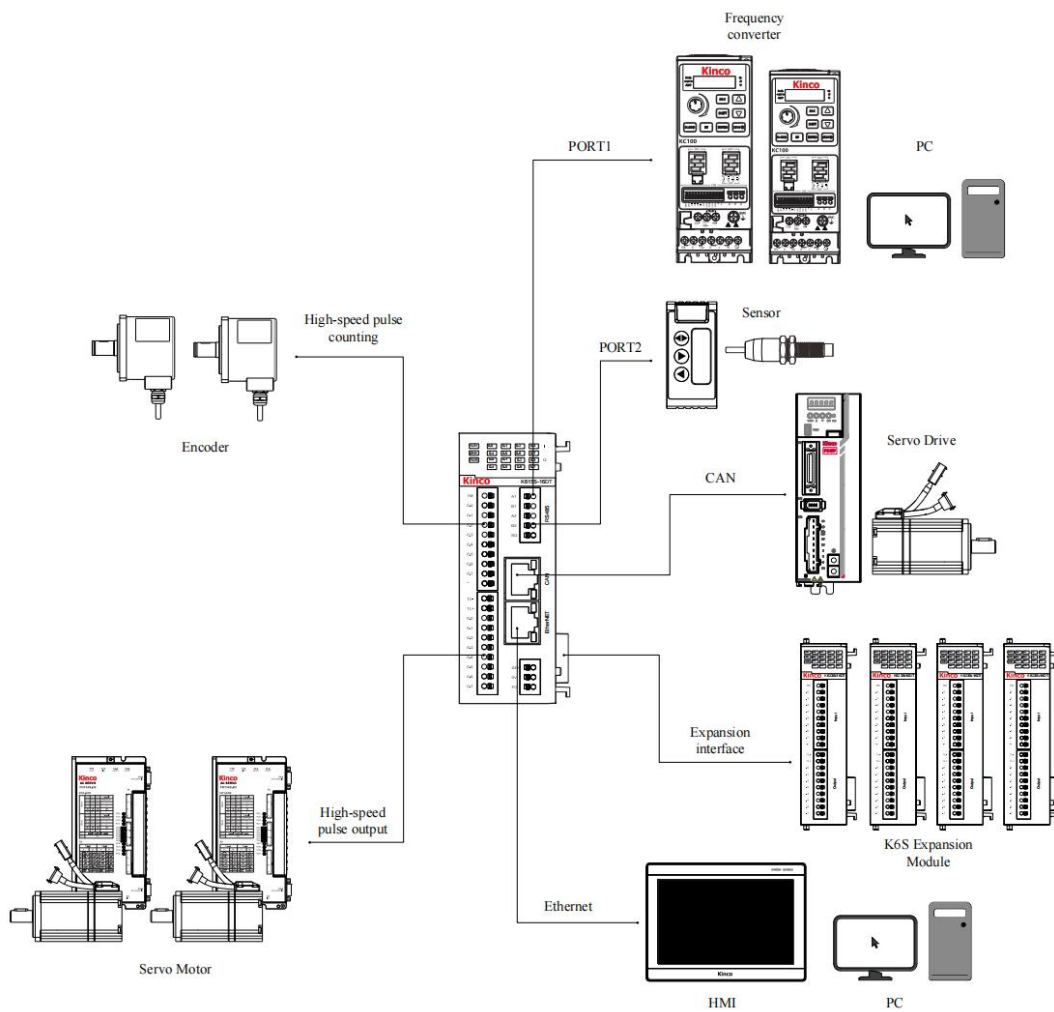

Figure 1.1-1 Example of the K 6 S series topology

1.2 Product naming and label

1.2.1 Product Naming Rules

In order to facilitate users to clearly identify and order, the "product model" of K6S is consistent with the "order number". The naming rules of the product "order number / product model" are as follows:

Module description identification + total number of channels + function identification,
with detailed description shown in Figure 1.2-1 below.

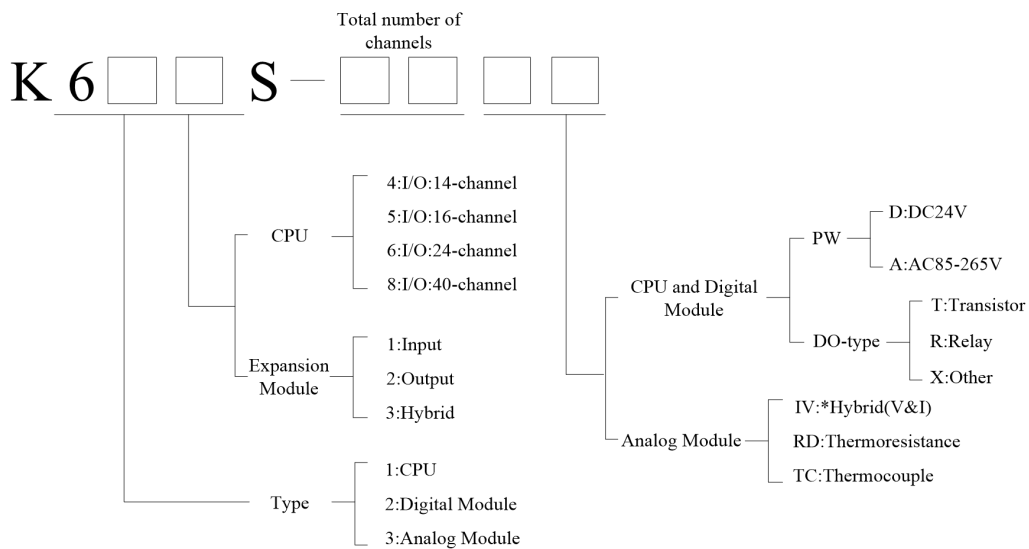

Figure 1.2-1 The naming rules of K 6 S series

According to the above principles, K615S-16D T represents 24V DC power supply, 16 point I / O (transistor output) CPU module; K623S-16DX represents 16 channel 24 VDC switch output expansion module.

1.2.2 Label information

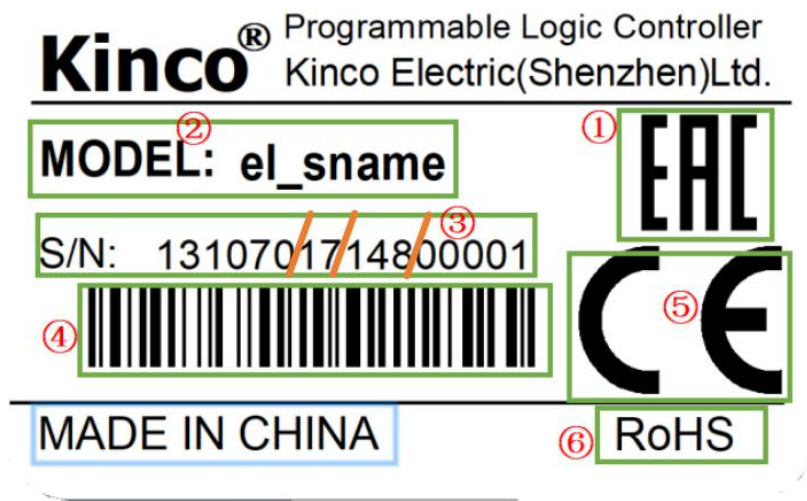

Figure 1.2-2 Label interpretation

Order number	meaning
①	EAC certification mark
②	Model of the product
③	Bits 1 to 6: Product code (unique for different models)
	7~8: Production year: 20 [xx], the figure above shows the production in 2017;
	Position 9~11: Production date: the [xxx] day, the figure above shows that the product was produced on day 148 of 2017;
	Bits 12~16: Production order of products: [xxx], the figure above shows that the product is the first product produced in the same model on the 148th day of 2017;
④	Product serial number Barcode
⑤	CE certification mark
⑥	RoHS certification mark

1.3 Working and storage conditions

The K6S series is designed to comply with the GB / T 15969.3-2007 (idt IEC61131-2:2007) standards and test specifications.

Transportation and storage		
climatic conditions	ambient temperature	-40°C ~ +70°C
	relative humidity	From 10% to 95%, with no condensation
	atmos	Equivalent to 0~3000 meters of altitude
Mechanical conditions	Free fall	With transport packing, allowed to fall to the cement floor 5 times from a height of 1 meter
going		
climatic conditions	ambient temperature	Open device for natural ventilation, ambient temperature-10~55°C
	relative humidity	From 10% to 95%, with no condensation
	atmos	The elevation is not exceeding 2,000 meters
	class of pollution	For pollution grade 2
Mechanical conditions	sinusoidal vibration	5<f<8.4Hz, Random: 3.5mm, displacement; continuous: 1.75mm displacement 8.4 <f <150, random: 1.0g acceleration; continuous: 0.5g acceleration
	lash	Semi-sine wave, 15g, 11ms, 6 times per axial direction
electromagnetic compatibility (EMC)	electrostatic discharge	Air discharge 8k V, contact discharge 4k V. Performance level B
	surge	AC power supply: 2k V CM, 1k V DM; The DC power supply is 0.5k V CM, 0.5k V DM; IO and communication port: 1 kVCM Performance level B.
	Fast transient pulse population	Power supply coupling 2k V, 5 kHz; IO and communication coupling 1k V, 5 kHz. Performance level B.

The K6S Series user manual

	Voltage drop	AC system, at 50Hz, voltage 0% for 1 wave, 40% for 10 wave, and 75% for 20 wave Performance level A
levels of protection	waterproof and dustproof	IP20

1.4 List of products

model	description
CPU module	
K615S-16DT	DC 24V Power supply; DI 8 * DC 24V (source type / leakage type), DO 8 * DC 24V (PNP); Support 3-road 200 KHz high-speed count input, 1 single phase 20 KHz / double phase 10 KHz; Support 3200 KHz high speed pulse output, 1 up to 10 KHz; Integrated communication interface: 2 * RS485, 1 * Ethernet, 1 * CAN; Up to the maximum support for 16 K6S module expansion;
Expand the module	
K621S-16DX	DI 16 * DC 24V (source type / leakage type);
K622S-16DR	DO 16 * relay;
K622S-16DT	DO 16*DC 24V(PNP);
K623S-16DT	DI 8 * DC 24V (source type / leakage type), DO 8 * DC 24V (PNP);
K622S-16DTN	DO 16*DC 24V (NPN)
K633S-06IV	12-bit resolution with a precision of 0.3% F.S.; AI*4: 4-20mA、1-5V、0-20mA 、0-10V ; AO*2: 4-20mA 、1-5V、0-20mA、0-10V ;
K631S-04TC	4*TC ; Support for types J, K, E, S, T, thermocouples, Cold end internal compensation and external compensation are optional; 24-bit resolution; precision 0.1% F.S. ;
K631S-04RD	4*RTD ; Support Pt 100, Cu 50, Pt1000 resistance form; Support the two-wire system, three-wire system wiring mode; 24-bit resolution; Temperature: $\pm 0.6^{\circ}\text{C}$; resistance: $\pm 1 \Omega$;

2. Product overview and hardware description

2.1 Introduction of K 6 S series

- Equipped with the new MCU platform, the execution speed is further improved. At the same time, the program storage space of 8k instructions and 20k bytes (V + M) are provided, which provides a guarantee for the implementation of complex control program.

- Integrated real-time clock (RTC), 4 high-speed pulse output (all channels support PTO \ PWM mode), 4 high-speed count input (support single / duplex, AB orthogonal count mode), 1 Ethernet interface, 2 RS485 interface, CAN and RS485 interface are isolated.

- Support array functions with up to 16 arrays and up to 1024 elements per array (elements can be any data type supported by K series PLC). Users can use the array function to find the maximum, minimum, average, sorting and other functions, and can also use the array to further expand the data storage space.

- Support stack functionality, with up to 2 stacks, each stack allowing up to 1024 elements (elements can be any data type supported by K-series PLC). Users can use the stack function to achieve the corresponding requirements, or they can use the stack to further expand the data storage space.

- Modular connection design, installation space can save more than 50%. On the right side, it can expand up to 16 extended modules, with rich types of modules, bringing users more and more flexible solutions.[\(Reference to the product list for specific module functions\)](#)

- KincoBuilder Software provides convenient and easy to use motion control instructions, more equipped with a wizard function, to help users to zero threshold to start, fast configuration, efficient programming.

- Standard with 10 / 100M Ethernet port, support Modbus TCP Client / Server

The K6S Series user manual

industrial bus protocol, TCP client / TCPserver free sending and receive, UDP peer free sending and receive, program upload download and firmware upgrade, suitable for multiple application requirements.

2.2 CPU module components and specifications

2.2.1 Function Description of the components

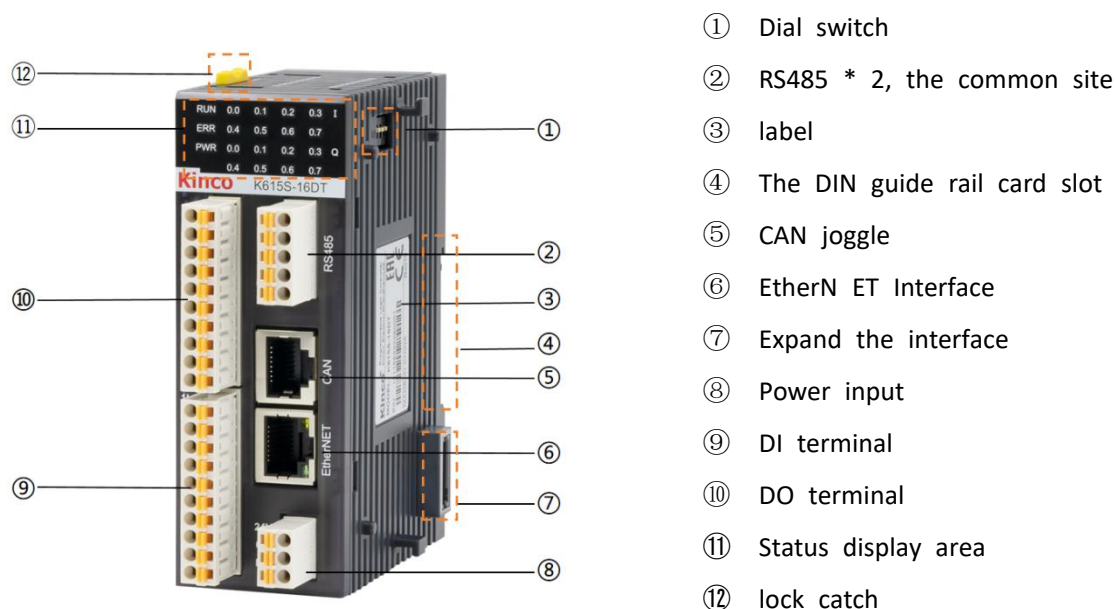

number	name	function
①	Dial switch	For the terminal resistance and for changing the operating state of the PLC. Please refer to: 2.2.1.1 Description of dial switch.
②	RS485 terminal terminal	5pin supports a total of 2 RS485, common.
③	label	Display the product model, serial number and other information
④	The DIN guide rail connection point	Can be installed on a standard DIN guide rail.
⑤	CAN joggle	For the CAN communication connections.
⑥	EtherNET Interface	For the Ethernet communication connections.
⑦	Expand the interface	For module expansion, please note that the module does not support hot plug. Please plug and plug the module when the CPU power supply is completely cut off.
⑧	Power input	24 The VDC power supply input terminal.
⑨	DI terminal	Input terminal connection, 8 DI (source / leakage).

⑩	DO terminal	Output terminal connection, 8-way DO (PNP).
⑪	Status display area	The CPU status is displayed, and the I / O terminal status is displayed.
⑫	lock catch	For fastening assembly or disassembly between modules.

2.2.1.1 Set-up code switch

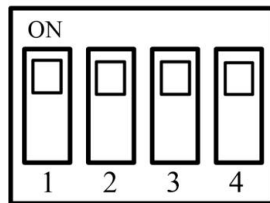

Figure 2.2-1 ial code switch

NO.	function	ON	OFF	Factory value
1	RS485 PORT1 Terminal resistance access / disconnection	Terminal resistance access	The terminal resistance is disconnected	OFF
2	RS485 PORT2 Terminal resistance access / disconnection	Terminal resistance access	The terminal resistance is disconnected	OFF
3	CAN terminal resistance access / off	Terminal resistance access	The terminal resistance is disconnected	OFF
4	The PLC state switching switch	move	cease	ON

- Way to change the CPU status
 - Move the no. 4 code switch on the right side of the CPU module to the ON identification side to move the CPU into the running state, otherwise enter the stop state;
 - [debug] in KincoBuilder software [start...] Or [stop...] Menu commands, as shown below.

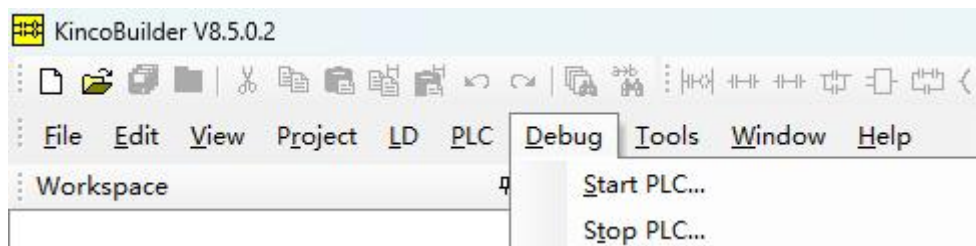



Figure 2.2-2 Switch over the PLC status

 Note: If the CPU detects a serious error during operation, it stops immediately.

2.2.1.2 RS485 interface

K615S-16DT module provides two RS485 serial communication interfaces, respectively named PORT 1 and PORT 2. All RS485 interfaces provide complete isolation in hardware design, so as to ensure the stability and reliability of communication work. The RS485 port is supported in the following table below ("√" indicates support and "-" indicates no support):

NO.	Modbus RTU	Programming debugging	Free communication
PORT1	√	√	√
PORT2	√	√	√

- Support 1-127 slave station number setting, the default address is 1;
- Support 1200bps to 115200bps baud rate setting;
- Support the master / slave mode;
- Up to 32 devices can be connected per communication.
- Both PORT 1 and PORT 2 can enable / disable the terminal resistance through the dial switch, see 2.2.1.1 for details.

2.2.1.3 CAN interface

CAN interface supports CANopen master station function, allowing a maximum of 64 slave stations, up to 8 TPDO and 8 RPDO configuration for each slave station, and supporting error control methods such as node protection and heartbeat.

The CAN interface supports the Kinco motion control protocol, which provides easy-to-use location control instructions and wizard configuration in the KincoBuilder. Users can easily connect to the Kinco's servo and step drive through the CAN bus. The Kinco motion control protocol supports connecting up to 16 nodes.

2.2.1.4 EtherNET interface

K615S-16DT module comes with 10 / 100M Ethernet port (meet IEEE802.3 standard specification), which is RJ 45. This interface supports programming protocol and can be used as a programming port. Support Modbus TCP Client / Server industrial bus protocol, TCP

client / TCPserver free transceiver, UDP peer free transceiver, program upload download and firmware upgrade, suitable for the application needs of multiple occasions.



pilot lamp	pigment	state	explain
green light	Grey green (go out) / green (bright)	Often bright	A 100M communication connection
		extinct	A 10M communication connection
		twinkle	There is currently a data sent and received
		Often bright	No data is currently received

The default factory IP for the K615S-16DT is 192.168.0.252. Users can use the Ethernet interface to communicate with PLC through Kincobuilder. Please refer to 4.6.1 PC and K615S-16DT for communication configuration.

2.2.1.5 Expand the interface

The expansion interface is a special expansion protocol interface, integrated power supply for IO module expansion. K615S-16DT CPU can support up to 16 module expansion, and users can choose it freely. Note that the expansion module does not support the hot-swap operation. Disassemble the module while ensuring that the CPU power is completely cut off.

2.2.1.6 State display area

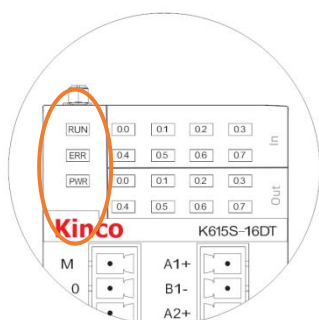

[RUN]: PLC operating status indicator, in normal operation, the RUN light is on (green light).

[ERR]: PLC error indicator light, detected by the user program or the CPU itself error, the ERR light is on (red light).

[PWR]: Power indicator light, under normal power voltage, PWR light is on (green light).

Figure 2.2-3 The PLC indicator lamp

- CPU pilot lamp

RUN, ERR and PWR are used on the K615S-16DT to indicate the current operation of the

CPU.

The status of K6S is listed in the following below:

pilot lamp	pigment	state	explain
RUN	Grey (put out) / green (bright)	Often bright	The PLC is in a running state
		twinkle	The PLC is in the firmware update mode
		extinct	The PLC is in a stopped state
ERR	Grey (put out) / red (bright)	Often bright	If an error occurs in the user program or the PLC itself, the user needs to view the specific error through the KincoBuilder
		extinct	PLC, user program detection of no errors
PWR	Grey (put out) / green (bright)	Often bright	The access power supply is normal
		extinct	If the power supply is abnormal, check the access power supply situation

The CPU divides errors into three levels: fatal error, serious error, and general error. When the CPU detects an error, light on the ERR light and store the specific error code in order according to the order of occurrence. The user can view the specific error information through the KincoBuilder programming software for analysis. For specific fault analysis, please refer to: 6.7 Error information and processing.

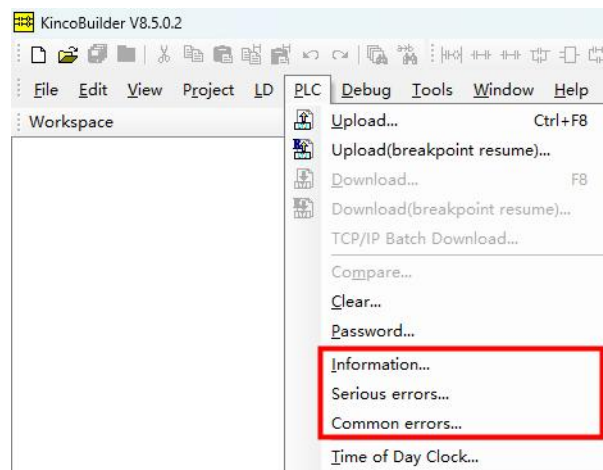

Figure 2.2-4 View the PLC information and errors

The CPU has two main states: running and stop. In the running state, the CPU module normally cycles out the main scan tasks and various interrupt tasks. In the stop state, the CPU module processes only some communication requests (including programming, debugging and other commands from KincoBuilder programming software, and communication commands as Modbus RTU stations in response to the master station), while

all output points (DO, AO) immediately output the "stop output" value defined in the user project [Hardware Configuration] of the user.

- I/O pilot lamp

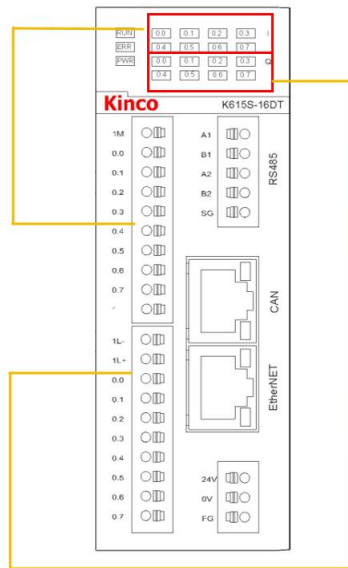

Figure 2.2-5 I / O light indicator

[I0.0~I0.7]: PLC body input status indicator light, gray (off) / green (bright), with external input, the light is on.

[Q0.0~Q0.7]: PLC body output status indicator light, gray (out) / green (on), if the control output is on.

2.2.1.7 Data retention and permanent storage

Data retention means that the data in the static random access memory (SRAM) is kept before (instantly) after the CPU off and available for use by the CPU at the next normal power on. The data retention function is to use a backup battery provided by the PLC internal CPU to maintain the power supply to maintain the SRAM memory data. Internal SRAM data read and write fast, and memory life is unlimited. But when the battery runs out, the data will be lost. At room temperature, the data can be maintained for no less than 3 years.

Users need to use KincoBuilder software to select the type of data area to be maintained (such as V, C, starting address, and length, and the maximum length of the user project can maintain all the data of V and C.

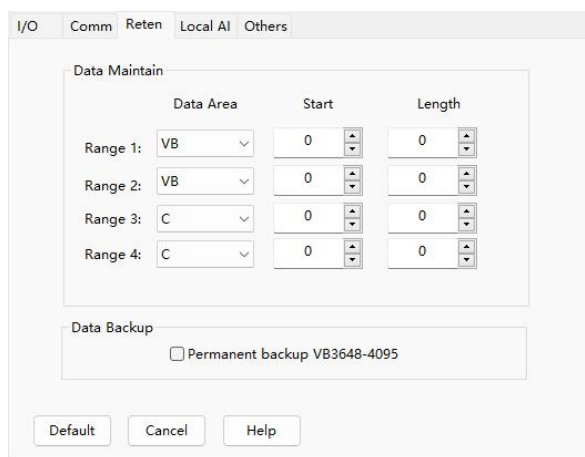

Figure 2.2-6, data hold settings

Permanent storage refers to the opening of an area in the permanent memory (EEPROM) of the CPU for storing user data. Data outage in the area will not be lost and permanently saved, but the permanent memory has life and write speed limits, so it cannot be written frequently and quickly.

The K-series PLC provides a data permanent storage area in Zone V, where the data is automatically written to the EEPROM, and the user can use these areas directly when programming. The data backup areas supported by K615S-16DT are VB3648-VB4095 and VB15360-VB16383. Users can select to enable / not an address segment in the engineering [PLC hardware configuration], as shown below:

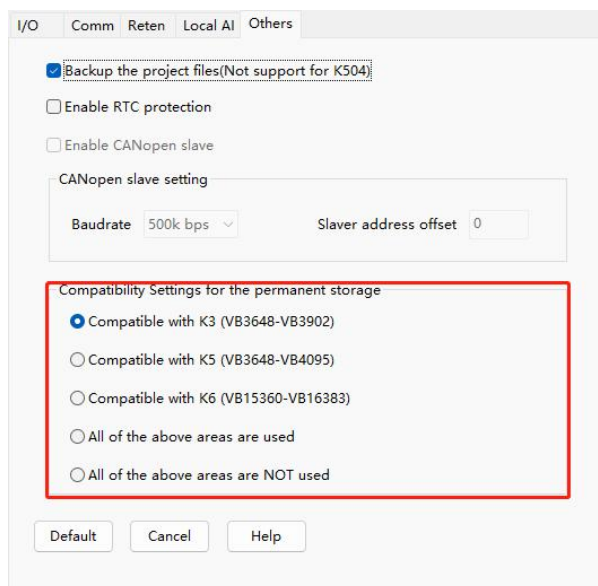

Figure 2.2-7, data hold settings

project	meaning
Compatible with K3 for permanent storage settings (VB3648-VB3902)	Selection indicates that VB3648-3092 takes effect as a data backup area where the data is automatically written into permanent memory. This K-series PLC is supported.

Compatible with K5 permanent storage settings (VB3648-VB4095)	Selection indicates that VB3648-4095 takes effect as a data backup area where the data is automatically written into permanent memory. This K series PLC is supported, except for K3.
Compatible with K6 permanent storage settings (VB15360-VB16383)	Selection indicates that VB15360-16383 takes effect as a data backup area, where the data is automatically written into the permanent memory. This item is only supported by K6S, K6, KS101M, and K209M.
All the areas above are stored automatically	This selection means that VB3648-4095 and VB15360-16383 simultaneously take effect as the data backup area, and the data in this area is automatically written into the permanent memory. This item is only supported by K6S and K6.
All of the areas above are not permanently stored	Check indicates that no permanent storage area is set. This item is only supported by K6S and K6.

2.2.1.8 Real-Time Clock (RTC)

The K615S-16DT integrates a real-time clock (RTC) to provide a real-time time / calendar representation. The format of the real-time clock / calendar (year / month / day, time / minute / second) is encoded in the BCD format and automatically makes a leap year adjustment. When the CPU is powered off, the real-time clock relies on the power supply of the backup battery to keep it running. At normal temperature, the typical life of the battery is 5 years, and the cumulative maintenance time of power outage is not less than 3 years.

During the first RTC, the user needs to execute [PLC] [adjust the CPU clock in KincoBuilder...] The menu commands to set the clock, then using the command (READ _ RTC, SET _ RT TC, RTC _ W, RTC _ R).

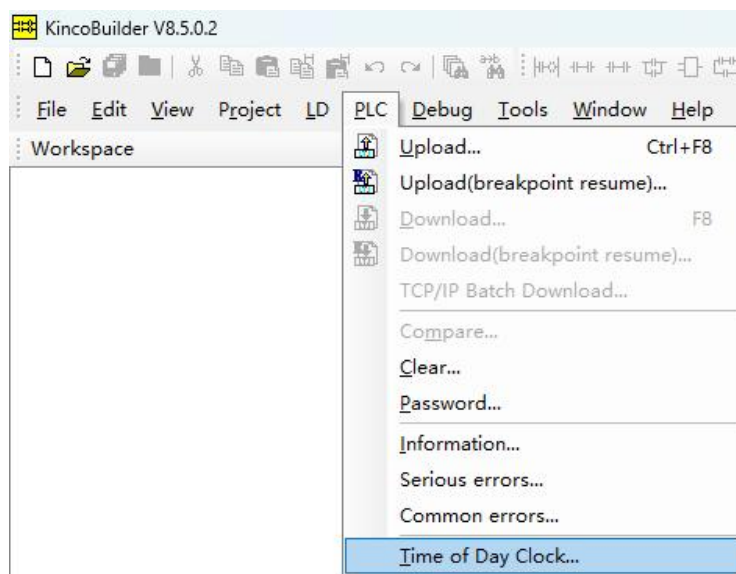

Figure 2.2-8 Adjust the CPU clock

- The RTC clock battery

The K615S-16DT uses a lithium battery of specific specifications as a backup battery. When the power is cut off, the backup battery is used to power the real-time clock to maintain the clock running, and also to the SRAM to maintain data.



Figure 2.2-9 RTC battery

When the battery power is low, an alarm information in the [PLC information] [Common error] of KincoBuilder will prompt the user to replace the backup battery.

The backup battery can be removed, but it needs to be replaced. After opening the shell, you can see the battery as in the right, and the user can replace it by himself.

The battery is CR20323V lithium battery with CR2032 connector. The physical display is shown in the right picture, and users can order the battery separately. For detailed ordering information, please contact the sales server.

2.2.1.10 High-speed counting function

K615S-16DT provides 4 high-speed pulse counting channels (HSC 0 to HSC 3). The highest count frequency of HSC 0, HSC 1 and HSC 2 is 200 kHz (single duplex / AB phase) and the highest count frequency of HSC 3 is 20 kHz / duplex 10 kHz.

- Working mode and hardware distribution of each channel

HSC0					
pattern	description	I0.1	I0.0	I0.5	
0	Single-phase increment / subtract counter with internal directional control Direction control bit: SM37.3	clock			
3	Single-phase increment / subtraction counter with external directional control	clock		direction	
6	Bi-phase counter with increase / subtract clock input	Clock (minus)	Clock (add)		
9	The A / B phase orthogonal counter	Clock A phase	Clock B phase		
HSC1					
pattern	description	I0.4	I0.6	I0.3	I0.2
0	Single-phase increment / subtract counter with			clock	

The K6S Series user manual

1	internal directional control Direction control bit: SM 47.3	reset			
3	Single-phase increment / subtraction counter with external directional control			clock	direction
6	Bi-phase counter with increase / subtract clock input			Clock (minus)	Clock (add)
9	The A / B phase orthogonal counter			Clock A	Clock B
10		reset		phase	phase
HSC2					
pattern	description	I0.4		I0.5	
0	Single-phase increment / subtract counter with internal directional control Direction control bit: SM 57.3			clock	
9	The A / B phase orthogonal counter	Clock B phase		Clock A phase	
HSC3					
pattern	description	I0.6		I0.7	
0	Single-phase increment / subtract counter with internal directional control Direction control bit: SM 127.3			clock	
9	The A / B phase orthogonal counter	Clock B phase		Clock A phase	

2.2.1.11 High-speed pulse output function

K615S-16DT provides 4 high-speed pulse output channels, where the highest output frequency of channel 0, channel 1 and channel 2 is 200 kHz, and the highest output frequency of channel 3 is 10 kHz. All channels support PTO (pulse string / pulse + direction) and PWM (pulse width modulation) output, while the software provides PLS (PWM or PTO), positioning control command group, PFLO _ F (follow command), etc., to facilitate users to achieve simple motion control applications.

- There are two ways to use a high-speed counter:
 1. The use of relevant instructions for programming: this way requires setting the corresponding control register in the program, and calling HDEF instructions and HSC instruction for programming, which is suitable for single-segment PV setting mode and multi-segment PV setting mode. Please refer to the programming manual for more detailed guidance cases.

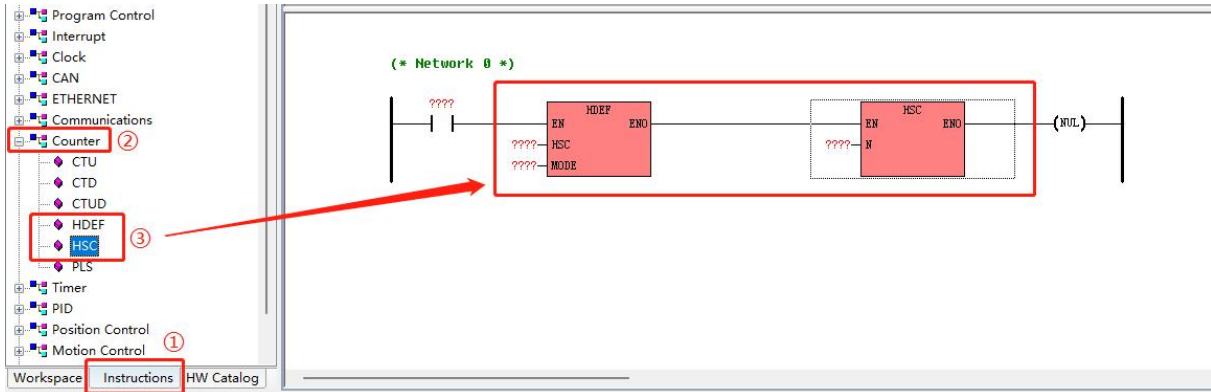

Figure 2.2-10, High-speed counter instruction

2. Use HSC wizard setting: this way is simple and intuitive only need to check the content provided in the wizard setting, it is suitable for single segment PV setting mode and multiple segment PV setting mode, it is recommended to use the wizard setting, simple and convenient to save programming time.

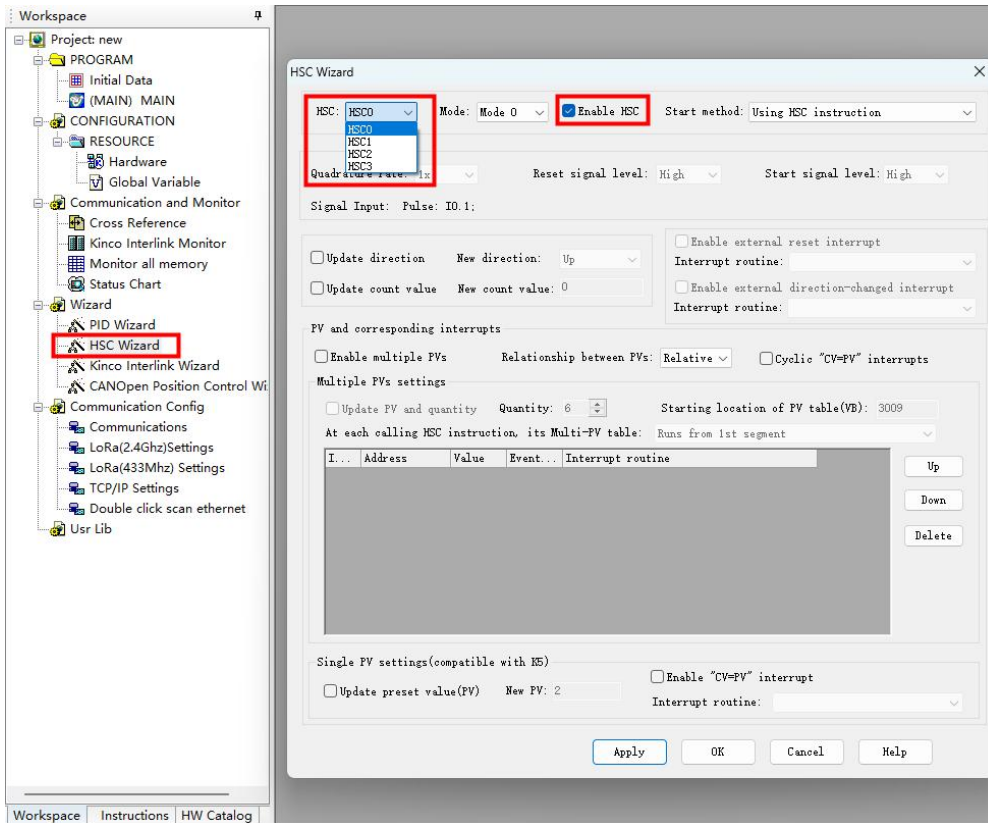

Figure 2.2-11 High-speed Count Wizard

● Hardware channel allocation

pattern	definition	channel 0	channel 1	channel 2	channel 3
PTO(pulse string)	outgoing channel	Q0.0	Q0.1	Q0.4	Q0.5

PTO	Pulse position	Q0.0	Q0.1	Q0.4	Q0.5
(Pulse + direction)	Directional position	Q0.2	Q0.3	Q0.6	Q0.7
PWM	outgoing channel	Q0.0	Q0.1	Q0.4	Q0.5

2.2.1.12 Interrupt function

The ontology input points IO.0 ~ IO.3 of K615S-16DT support the edge interrupt function, which can use the rising edge and descending edge of the input signal to generate the interruption. This work can quickly capture the rising edge or descending edge of the input, and achieve a rapid response to some input signals whose pulse width is less than the CPU scan cycle. Please refer to the programming manual for more detailed guidance cases.

2.3 Functional description of expanded module components

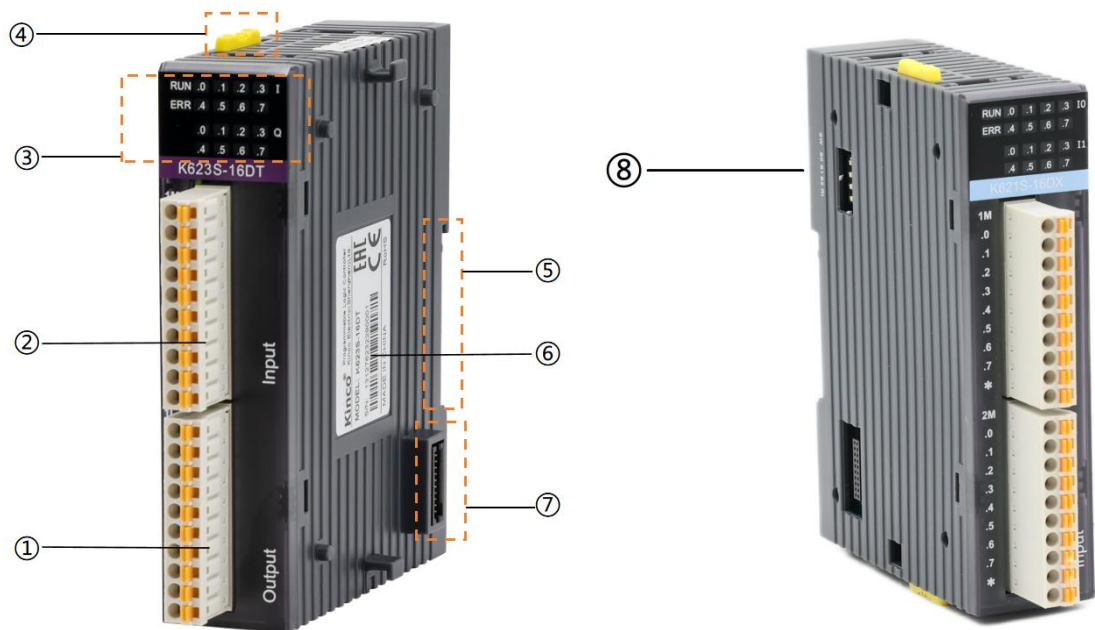

- ①binding post ②binding post ③Status display area ④lock catch ⑤The DIN track card slot
⑥label ⑦Expand the interface ⑧DIP switch

number	name	function
①/②	binding post	DI, DO, AI, AO terminal wiring, specific wiring please refer to the specific model.

③	Status display area	<p>The I / O terminal status display:</p> <p>DI / O: the digital quantity channel is up to indicate on, extinguished is not connected;</p> <p>AI: The analog input channel is illuminated as the input / output overrun.</p>
④	lock catch	For fastening assembly or disassembly between modules.
⑤	The DIN guide rail connection point	Can be installed on a standard DIN guide rail.
⑥	label	Display the product model, serial number and other information
⑦	Expand the interface	For module connection, please note that the module does not support live plug. Please disassemble the module if the CPU power failure is confirmed.
⑧	DIP switch	A dial switch is provided on the left side of the module, with Rt representing the termination resistor for the expansion bus. In normal applications, it is recommended to switch the terminal of the last module to ON to activate the termination resistor. This will improve the anti-interference capability of the expansion bus, reduce signal reflection, and enhance signal quality, thereby ensuring the stable and reliable operation of the expansion module.

3 Technical parameters

3.1 CPU K615S-16DT

● Power specifications

Power supply voltage range	24V DC (± 20%)
Maximum current of the power supply source	1.2A (with 16 extended modes)
Ontology rated power	5W
power protection	Provide short-circuit protection and backcontact protection

● Ontology DI specifications

Enter the type	Source / leakage type
----------------	-----------------------

The K6S Series user manual

Number of input channels	8 channel Support for 4-channel high-speed pulse input Support the AB phase, P (pulse) / D (direction) mode The highest frequency of 3 input is 200 kHz, and the highest frequency of 1 input is 10 kHz \ single phase 20 kHz
input voltage	24V DC
input impedance	5.4k
Logical "0" maximum input voltage	5V , 0.8mA
Logic "1" minimum input voltage	11V , 2mA
Enter the delay time	<2.5uS
isolation method	Digital isolation, 500VAC / 1 min
State instructions	With the input signal, the corresponding LED light is on

● Ontology DO specifications

Output type	transistor PNP
Number of output channels	8 channels, support 4-channel high-speed pulse output, support PWM function The highest output frequency of 3 is 200 kHz (load current is greater than 20mA), and the highest frequency of 1 is 10kHz
Output current per channel	Maximum of 300mA @24VDC
Output leakage current	Maximum of 10 μ A
output impedance	Maximum of 0.3 Ω
Output delay time	<5uS
defensive function: • Emotional load output protection • short-circuit protection	have have
Channel parallel function	Yes (within the same group)
isolation method	Photoelectric isolation, 500VAC / min
State instructions	With the output signal, the corresponding LED light is on

● CI

The K6S Series user manual

RS485	2-way RS 485, isolated PORT1 Support programming protocol, Modbus RTU protocol master / slave station, free communication PORT2 Support programming protocol, Modbus RTU protocol master / slave station, free communication
Ethernet	1 road, support Modbus TCP Client / Server, Modbus UDP industrial bus protocol, TCP client / TCPserver free sending and receive, UDP peer free sending and receive, program upload download and firmware upgrade
CAN	1 Road Supports CAN open, CAN free communication Support for the Kinco motion control function
Ontology extension bus ¹	Support up to 16 K6S extension modules

● Program storage and the RTC

user program	Maximum of 8k instructions
User data	4k byte in M; 16k byte in V
timer	A total of 256 were for each study 1ms time-base: 4 units 10ms time-base: 16 units 100ms time-base: 236 units
counter	256 The
backup	E E PROM, 1k-byte
data-hold	Area V: VB0-VB1907:1908 bytes Zone C: C0-C63 Lithium battery, stay at room temperature for 3 years
RTC	The operating environment is less than 5 min / month at 25°C
cell	Support the battery voltage monitoring, can replace the battery

¹Expansion bus: used to connect CPU module and expansion module, the physical medium of this product uses pin-socket. Integrate the working power supply with the data bus, the address bus and the extension module in the extension bus

3.2 Extended expansion module

3.2.1 K621S-16DX

K621S-16DX module is a universal digital input module with 16 channels, including 2 groups (8 channels / group) universal transistor input and support source / leakage type.

- Power specifications

The module is connected by an extended interface and communicates through the dedicated bus protocol. The module power supply has been integrated in the dedicated bus without external wiring.

- DI specifications

Enter the type	Source / leakage type
Number of input channels	16 (8-channel / group)
input voltage	DC 24V
Logical "0" maximum input voltage	5V, 0.8mA
Logic "1" minimum input voltage	11V, 2mA
Enter the delay time	
• Connect delay	Less than 18 μ s
• Disconnect latency	Less than 50 μ s
isolation method	Photoelectric isolation, 500VAC / 1 min
State instructions	With the input signal, the corresponding LED light is on
DI image zone	2 Bytes

3.2.2 K622S-16DR

The K622S-16DR module is a relay output module with 16 channels, including 4 groups (4 channels / group) relay output.

- Power specifications

The module is connected by an extended interface and communicates through the dedicated bus protocol. The module power supply has been integrated in the dedicated bus without external wiring.

- DO specifications

Number of output channels	16 Relay (4 channels / group)
---------------------------	-------------------------------

Allow load voltage	DC 24V / AC 250V
Allowable load current (resistance load)	2A / point, and 4A / group
Allowable load current (inductive load)	1A / point, and 4A / group
Output-on delay time	10ms (max.)
Output disconnection delay time	5ms (max.)
Relay contact life expectancy	
• Mechanical life (no-load)	20,000,000 times (1,200 times / min)
• Electrical life (rated load)	1000,000 times (6 times / min)
Output isolation features	
• isolation method	electric relay
• Isolation voltage between the coil and the contact	2000Vms
State instructions	With the output signal, the corresponding LED light is on
DO image zone	2 Bytes

3.2.3 K622S-16DT

The K622S-16DT module is a digital output module with 16 channels, including 2 groups (8 channels / group) transistor PNP output.

- Power specifications

The module is connected by an extended interface and communicates through the dedicated bus protocol. The module power supply has been integrated in the dedicated bus without external wiring.

- DO specifications

Output type	transistor PNP
Number of output channels	16 (8-channel / group)
output voltage	DC 24V。 Allowed range: DC20.4V-DC28.8V
Output current per channel	Maximum of 300 mA @ 24 VDC
Output leakage current	Maximum of 10 μ A
output impedance	Maximum 0.2 Ω

Output delay time	
• Connect delay	Less than 30 μ s
• Disconnect latency	Less than 50 μ s
defensive function:	
• Emotional load output protection	have
• short-circuit protection	have
• Output polarity in reverse protection	Yes, allow to apply the reverse polarity signal at the output for no more than 10s
Channel parallel function	Yes (within the same group)
isolation method	Photoelectric isolation, 500VAC / 1 min
State instructions	With the output signal, the corresponding LED light is on
DO image zone	2 Bytes

3.2.4 K623S-16DT

The K623S-16DT module is a universal digital input / output hybrid module with 16 channels including a set of 8 transistors input with source / leakage type / support type; a set of 8 transistors output and supporting PNP type.

- Power specifications

The module is connected by an extended interface and communicates through the dedicated bus protocol. The module power supply has been integrated in the dedicated bus without external wiring.

- DI specifications

Enter the type	Source / leakage type
Number of input channels	8 (8-channel / group)
input voltage	DC 24V
Logical "0" maximum input voltage	5V, 0.8mA
Logic "1" minimum input voltage	11V, 2mA
Enter the delay time	
• Connect delay	Less than 18 μ s
• Disconnect latency	Less than 50 μ s
isolation method	Photoelectric isolation, 500VAC / 1 min

State instructions	With the input signal, the corresponding LED light is on
DI image zone	1 Bytes

● DO specifications

Output type	transistor PNP
Number of output channels	8 (8-channel / group)
Output current per channel	Maximum of 300 mA @ 24 VDC
Output leakage current	Maximum of 10 μ A
output impedance	Maximum 0.2 Ω
Output delay time	
• Connect delay	Less than 30 μ s
• Disconnect latency	Less than 50 μ s
defensive function:	
• Emotional load output protection	have
• short-circuit protection	have
• Output polarity in reverse protection	Yes, allow to apply the reverse polarity signal at the output for no more than 10s
Channel parallel function	Yes (within the same group)
isolation method	Photoelectric isolation, 500VAC / 1 min
State instructions	With the output signal, the corresponding LED light is on
DO image zone	1 Bytes

3.2.5 K622S-16DTN

The K622S-16 DTN module is a digital output module with 16 channels, including 2 groups (8 channels / group) transistor NPN output.

● Power specifications

The module is connected by an extended interface and communicates through the dedicated bus protocol. The module power supply has been integrated in the dedicated bus without external wiring.

● DO specifications

Output type	transistor NPN
Number of output channels	16 (8-channel / group)
output voltage	DC 24V。 Allowed range: DC20.4V-DC28.8V

Output current per channel	Maximum of 300 mA @ 24 VDC
Output leakage current	Maximum of 10 μ A
output impedance	Maximum 0.3 Ω
Output delay time	
• Connect delay	Less than 30 μ s
• Disconnect latency	Less than 50 μ s
defensive function:	
• Emotional load output protection	have
• short-circuit protection	have
• Output polarity in reverse protection	Yes, allow to apply the reverse polarity signal at the output for no more than 10s
Channel parallel function	Yes (within the same group)
isolation method	Photoelectric isolation, 500VAC / 1 min
State instructions	With the output signal, the corresponding LED light is on
DO image zone	2 Bytes

3.2.6 K633S-06IV

K623-06IV module is a hybrid module with 4 analog input and 2 analog output, both supporting the input measurement or output of voltage or current signal (4-20 mA, 1-5V, 0-20 mA, 0-10V).

3.2.6.1 Technical parameters

AI number of channels	4
Signal form	4-20mA 、 1-5V 、 0-20mA 、 0-10V
resolution ratio	12 bits
certainty of measurement	0.3% F.S.
Signal limit	Current input not exceed 24 mA and voltage input not exceed 12V
Conversion rate (per channel)	About 15 beats / s
input impedance	Current mode: 250 Ω Voltage mode:> 4M Ω
AO number of channels	2
Signal form	4-20mA 、 1-5V 、 0-20mA 、 0-10V
Resolution (with symbolic	12 bits

bits)	
Output signal accuracy	0.3% F.S.
Conversion rate (per channel)	About 15 times / s
external loading	Current mode: 500 Ω Voltage mode: Minimum of 10K Ω
else	
State instructions	The AI corresponding channel red LED indicates that the input value is outside the selected range
Occupy address space	
AI image area	8 bytes (2 bytes per channel)
AO image area	4 bytes (2 bytes per channel)

3.2.6.2 Measurement range and measurement value representation format

After the input signal of each channel passes through ADC sampling and linear calculation, the calculation results are sent to the CPU through the extension bus as the measured value, and the AI image area of the module is used for access by the user program. Different signal forms have their measurement range. If the measured value exceeds the rated measurement range, the module will alarm: if the channel LED exceeds the range, the light will be on (red). At the same time, the module will automatically send a fault message to the CPU module through the expansion bus.

It is suggested that users will not use AI channel group terminal short, and in the programming software the group of corresponding signal form set to [0-20mA] or [0-10V], artificially let the group of channel pin in signal acquisition state, and in the form of short gather charge discharge, to prevent interference, caused by false alarm, short connect only the three terminals of the same channel short:

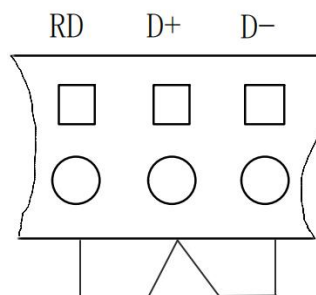

Figure 3.2.6-1 Analog quantity input short connection diagram

The following table is the measurement range and measurement value representation format, where I represents the input current value and V represents the input voltage value.

Signal form	measuring range	Measured values represent the format
4~20mA	3.92~20.4mA	$I \times 1000$ (3920~20400)
0~20mA	0~20.4mA	$I \times 1000$ (0~20400)
1~5V	0.96~5.1V	$V \times 1000$ (960~5100)
0~10V	0~10.2V	$V \times 1000$ (0~10200)

The AQ output value specified in the user program is first sent to the corresponding AO module through the extension bus, and then calculated, transformed and output to the specified channel through the DAC. The output of different signal forms has its rated range. If the output value specified in the user program exceeds the upper and lower limits of the selected range, the corresponding values of the above and lower limits are still output.

The following table is the output range and output value representation format, where I represents the actual current value and V represents the actual voltage value.

Signal form	output range	The output value specified in the user program
4~20mA	3.92~20.4mA	$I \times 1000$ (3920~20400)
0~20mA	0~20.4mA	$I \times 1000$ (0~20400)
1~5V	0.96~5.1V	$V \times 1000$ (960~5100)
0~10V	0~10.2V	$V \times 1000$ (0~10200)

3.2.7 K631S-04TC

K631S-04TC module has 4 measurement channels, all of which support type J, type K, type E, type S, and type T thermocouple signal measurement, and the internal and external compensation of measuring cold end is optional. The signal form of the channel is configured in the programming software KincoBuilder.

Note: The temperature measuring element of the cold end is integrated in the module. When the internal compensation method is selected, the measurement result of the cold end will be affected by the heating when the module works. Due to the slow temperature rise of the product, the time required for the stability of the cold end in different environments is different, it usually takes 40-50 minutes to achieve the stability, which will lead to the large error of the measured temperature value of the channel (the maximum error may reach about 8°C). In addition, the installation of different modules on the left and

right sides of the temperature module will also affect the cold end value. When the left and right sides of the module are the temperature module (K631S-04RD / TC), the error of the cold end compensation is small, and when the left and right sides are non-temperature modules, the error of the cold end compensation is slightly larger. The maximum error of the internal compensation mode (after the cold end temperature is stable) is within 6°C.

3.2.7.1 Technical parameters

number of channels	4
Signal form	Type J, K, E, S, and T
Compensation form	Internal compensation and external compensation of the cold end are optional
Resolution (with symbolic bits)	24 bits
certainty of measurement	0.1% F.S.
Conversion rate (per channel)	About 1 time / second
input impedance	>20K Ω
State instructions	Each channel red LED indicates that the input value is outside the selected range
Occupy address space	
AI image area	8 bytes (2 bytes per channel)
AO image area	-

3.2.7.2 Measurement range and measurement value representation format

The obtained value of the input signal of each channel after A / D conversion will be calculated and converted according to the standard thermocouple separation table, and the results will be sent to the extension bus through the CPU in the AI area of the module for access by the user program.

Different signal forms have their measurement range. If the measured value exceeds the rated measurement range, the module will alarm: the channel LED lamp beyond the range will be on (red), and the module will automatically send a fault message to the CPU module through the expansion bus. The following table is the measurement range and measurement value representation format, where T represents the measured temperature value.

Signal form	measuring range	Measured values represent the format
J mould	-210~1200°C	$T \times 10$ (-2100~12000)

K mould	-270~1300℃	T×10 (-2700~13000)
E mould	-270~1000℃	T×10 (-2700~10000)
S mould	-50~1600℃	T×10 (-500~16000)
T mould	-260~400℃	T×10 (-2600~4000)

3.2.8 K631S-04RD

The K631S-04RD module has four channels, which supports two and three-line thermal resistance temperature measurement of Pt 100, Pt1000, and Cu 50, and also supports direct measurement of resistance value. The signal form of the measurement channel shall be configured in the programming software KincoBuilder.

3.2.8.1 Technical parameters

number of channels	4
Rated power supply	DC 24V , ≥100mA
Signal form	Pt 100, Cu 50, Pt1000, and resistance
Terminal form	Two-line system, three-line system
Resolution (with symbolic bits)	24 bits
certainty of measurement	Temperature: $\pm 0.6^{\circ}\text{C}$; resistance: $\pm 1 \Omega$
Conversion rate (per channel)	About 1 time / second
State instructions	Each channel red LED indicates that the input value is outside the selected range
Occupy address space	
AI image area	8 bytes (2 bytes per channel)
AO image area	-

3.2.8.2 Measurement range and measurement value representation format

After the input signal of each channel passes through ADC sampling and linear calculation, the calculation results are sent to the CPU through the extension bus as the measured value, and the AI image area of the module is used for access by the user program. Different signal forms have their measurement range. If the measured value exceeds the rated measurement range, the module will alarm: the channel LED lamp beyond the range will be on (red), and the module will automatically send a fault message to the CPU module through the expansion bus.

The following table is the measurement range and measurement value representation

The K6S Series user manual

format, where I represents the input current value and V represents the input voltage value.

Signal form	measuring range	Measured values represent the format
Pt100	-200~850°C	$T \times 10(-2000 \sim 8500)$
Cu50	-50~150°C	$T \times 10(-500 \sim 1500)$
Pt1000	-50~300°C	$T \times 10(-500 \sim 3000)$
resistance	0~2000 Ω	$R \times 10(0 \sim 20000)$

4 Wiring and dimensions

4.1 Wiring instructions

4.1.1 K615S-16DT

4.1.1.1 Power supply wiring instructions

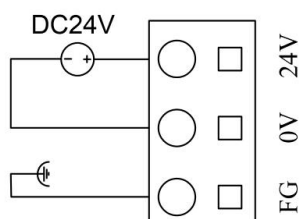
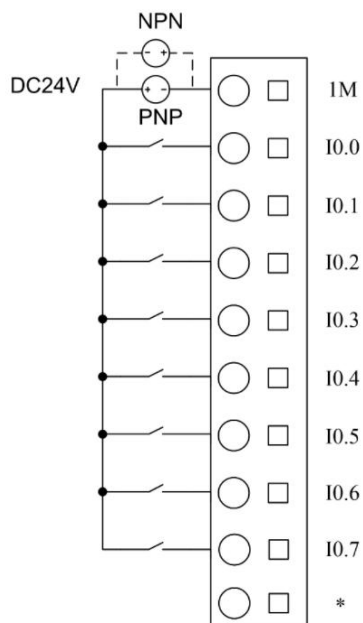

Figure 4.1.1-1 Power supply terminal

Silk printing symbol	meaning
24V	24 The VDC power supply main end
0V	24 The VDC power supply reference place
	Protected ground (connecting to the earth)

After the module has normal power supply, the LED on the upper module and the [PWR] indicator in the lamp will appear in green.

4.1.1.2 Wiring description of body DI



The body input of K615S-16DT supports the source type and leakage wiring mode, with the common end 1M of the input end as the reference point, and the signal flows from the common end (1M point) into the source type input (PNP), that is, the signal high level is effective;

The signal flows out from the common end (1M point) of the input signal end, which is called the leakage input (NPN), that is, the signal low level is effective.

In the left figure, the solid line is the source type input

Figure 4.1.1-2 K615S-16DT module DI wiring

external wiring, and the dotted line is the leaky type input external wiring diagram.

symbol	meaning	symbol	meaning
1M	24V DC power supply positive end (source type)	I0.4	Universal / high-speed input
	24V DC power supply reference ground (leakage type)		
I0.0	Universal / high-speed input	I0.5	Universal / high-speed input
I0.1	Universal / high-speed input	I0.6	Universal / high-speed input
I0.2	Universal / high-speed input	I0.7	Universal / high-speed input
I0.3	Universal / high-speed input	*	Hanging, no definition

4.1.1.3 Body DO wiring description

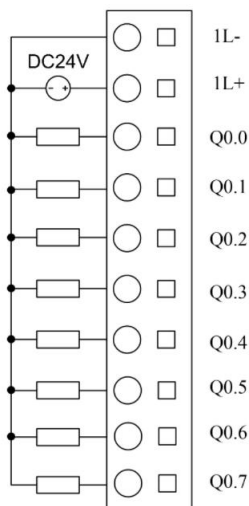

The output of the body transistor of the K615S-16DT only supports the PNP output mode, and the picture on the left shows the external wiring of the PNP output. PNP is the signal output line when a signal is triggered.

Figure 4.1.1-3 K615S-16DT module

symbol	meaning	symbol	meaning
1L-	24 The VDC power supply reference place	Q0.3	be in common use
1L+	24 The VDC power supply main end	Q0.4	Universal / high-speed output
Q0.0	Universal / high-speed output	Q0.5	Universal / high-speed output
Q0.1	Universal / high-speed output	Q0.6	be in common use
Q0.2	be in common use	Q0.7	be in common use

4.1.1.4 RS485 wiring instructions

K615S-16DT module provides two serial communication interfaces, communication ports are named PORT 1, PORT 2, all RS485 ports provide complete isolation on the hardware, so as to ensure the stability and reliability of communication work. RS485 The communication port has the highest port rate of 115200bps, supports Modbus RTU master,

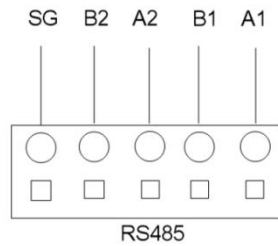

slave protocol and free communication, and each RS485 interface supports up to 32 devices networking.

Figure 4.1.1-4 K 615 terminal RS485 of the S-16DT module

symbol	meaning
SG	Signal reference
B2	Group 2, TXD- / B
A2	And 2 groups of TXD + / A
B1	In Group 1, the TXD- / B
A1	In Group 1, the TXD + / A

The bus-type extension structure of RS485 is shown below. It is recommended that customers add 120 Ω terminal resistance at the first and last ends of the bus (the RS485 interface of K615S-16DT comes with terminal resistance, which can be enabled / disabled by dialing code).

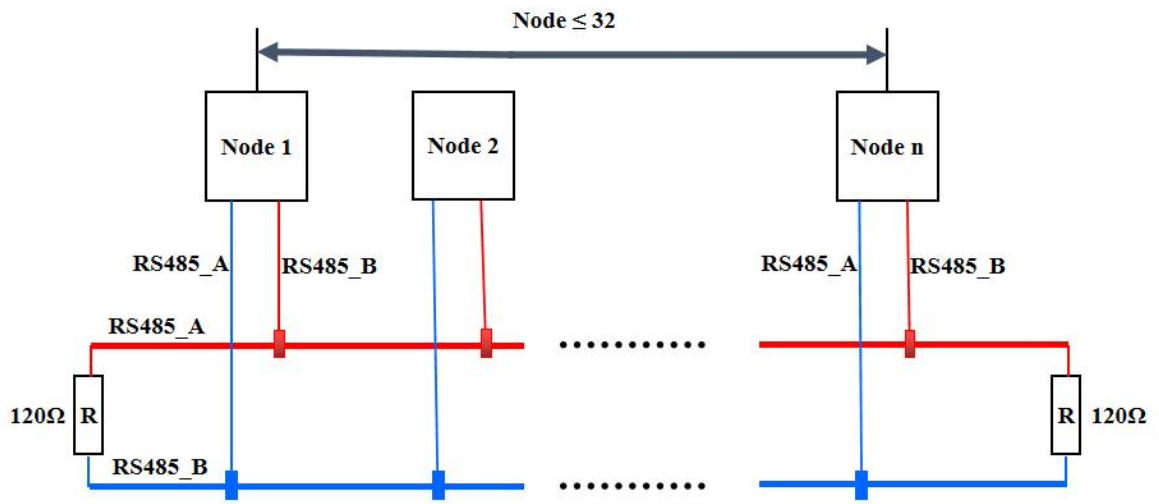

Figure 4.1.1-5 RS485 extension

4.1.1.5 EtherNET wiring instructions

EtherNET The communication cable adopts direct cable (through line) or cross cable (cross line). The Ethernet interface on the CPU module provides the "automatic negotiation" function. When the cable is inserted, it automatically negotiwith the communication party to determine the type of cable used.

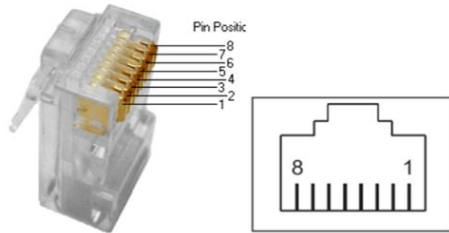

Figure Figure 4.1.1-6 EtherNET RJ45 line number description

Pin	signal	description
1	TD+	transmit by radio +
2	TD-	transmit by radio-
3	RD+	receive +
4		
5		
6	RD-	receive-
7		
8		

4.1.1.6 CAN wiring instructions

When actually wiring the CAN bus, it is recommended to use the topology of the bus type, and in order to reduce the signal reflection on the communication cable, it is recommended to dial up the 120 Ω terminal resistance of the CPU at the first and last ends of the bus (please refer to the 2.2.1.1 dial switch). When the communication distance is long, it is recommended to use shielded twisted pair cable and the single end of the shielding layer is well grounded (control place), and the communication cable should be far away from strong interference sources, various high power lines (including power cables of equipment), pulse signal lines with frequent switches, etc.

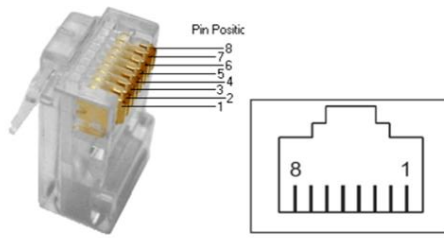

Figure Figure 4.1.1-7 CAN RJ45 line number description

Pin	signal	description
1	CAN_H	CAN bus signal, high level
2	CAN_L	CAN bus signal, low level
3	CAN_GND	The CAN bus signal ground

When use, the user needs to connect the CAN _ H and CAN _ L pins of all nodes in the network together. The CAN bus topology structure is shown in the figure below. If the common mode voltage difference is large between nodes, the CAN _ GND of all nodes in the network can be connected together during the application, so that all nodes can have a unified reference potential, so as to eliminate or reduce the common mode voltage and avoid the bus communication faults caused by the common mode interference. The CAN bus communication distance is inversely proportional to the communication rate. When the communication rate is 10k, the theoretical maximum communication distance L is 1km; when the communication rate is 1M, the theoretical maximum communication distance L is 25m.

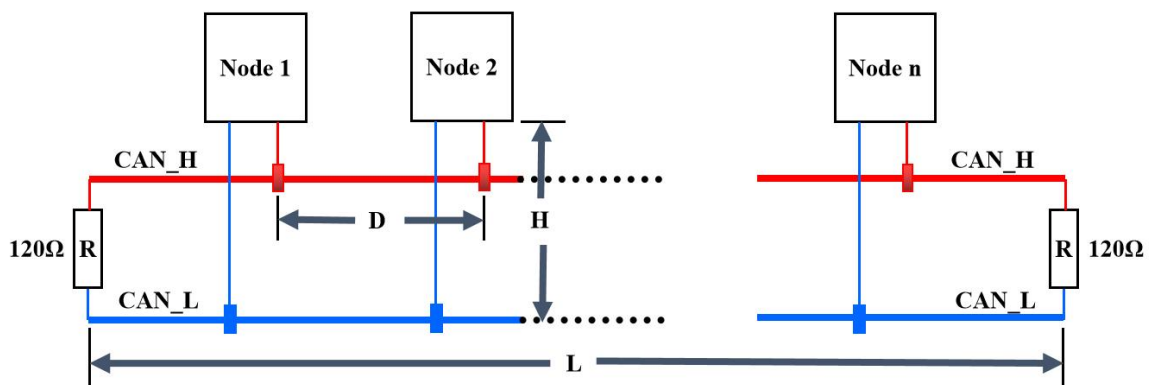

Figure 4.1.1-8 The CAN topology structure

4.1.2 K621S-16DX

- Power wiring instructions

The module is connected by an extended interface and communicates through the dedicated bus protocol. The module power supply has been integrated in the dedicated bus without external wiring.

- DI wiring instructions

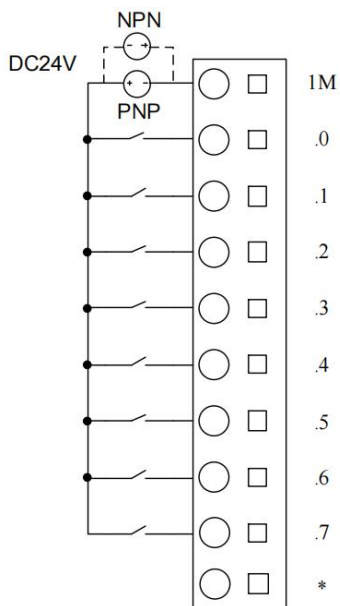

The input channel of K621S-16DX module supports the source type and leakage wiring mode, with the common end of the input end 1M as the reference point, and the signal flows from the common end (1M point) into the source type input (PNP), that is, the signal high level is effective;

The signal flows out from the common end (1M point) of the input signal end, which is called the leakage input (NPN), that is, the signal low level is effective.

In the left figure, the solid line is the source type input external wiring, and the dotted line is the leaky type input external wiring diagram.

Figure 4.1.2-1 K621S-16DX module DI wiring

4.1.3 K622S-16DR

- Power wiring instructions

The module is connected by an extended interface and communicates through the dedicated bus protocol. The module power supply has been integrated in the dedicated bus without external wiring.

- DO wiring instructions

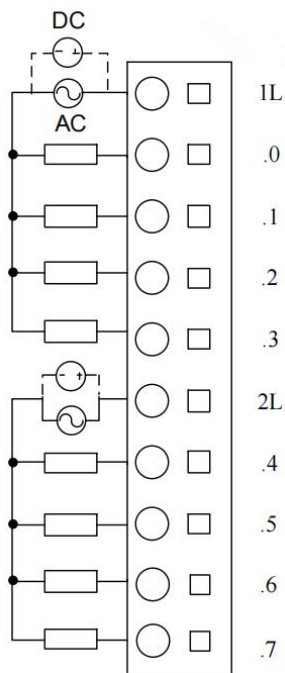

K622S-16DR module only supports relay type output, the left picture is the output wiring diagram.

Figure 4.1.3-1 K622S-16 DO wiring of the DR module

4.1.4 K622S-16DT

- Power wiring instructions

The module is connected by an extended interface and communicates through the dedicated bus protocol. The module power supply has been integrated in the dedicated bus without external wiring.

- DO wiring instructions

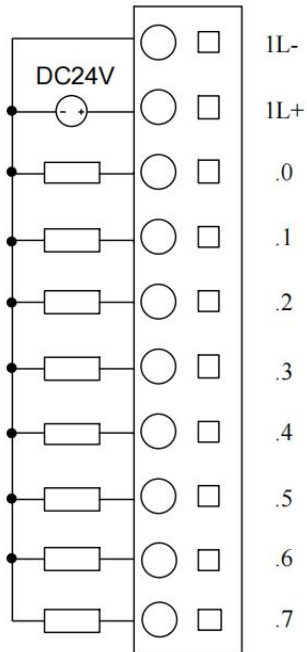

The transistor output of K622S-16DT module only supports PNP output mode, and the left picture shows the external wiring of PNP output. PNP is the signal output line when a signal is triggered.

Figure 4.1.4-1 K622S-16DT module DO wiring

4.1.5 K623S-16DT

- Power wiring instructions

The module is connected by an extended interface and communicates through the dedicated bus protocol. The module power supply has been integrated in the dedicated bus without external wiring.

- DI wiring instructions

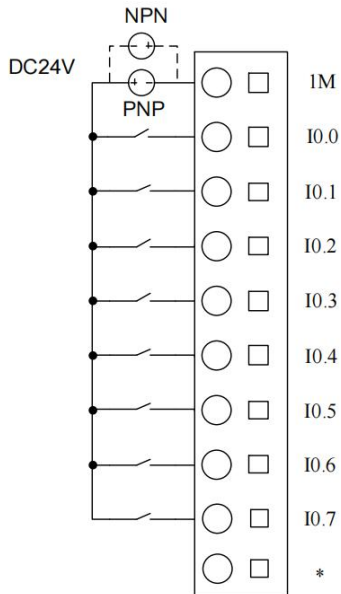

The input channel of K623S-16DT module supports the source type and leakage wiring mode, with the common end of the input end 1M as the reference point, and the signal flows from the common end (1M point) into the source type input (PNP), that is, the signal high level is effective;

The signal flows out from the common end (1M point) of the input signal end, which is called the leakage input (NPN), that is, the signal low level is effective.

In the left figure, the solid line is the source type input external wiring, and the dotted line is the leaky type input external wiring diagram.

1 K623S-16DT module DI

- DO wiring instructions

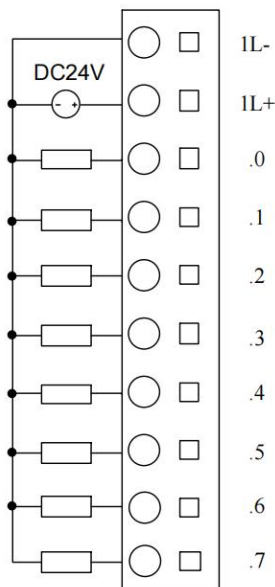

The transistor output of K623S-16DT module only supports PNP output mode, and the left picture shows the external wiring of PNP output. PNP is the signal output line when a signal is triggered.

Figure 4.1.5-2 K623S-16DT module DO

4.1.6 K622S-16DTN

- Power wiring instructions

The module is connected by an extended interface and communicates through the dedicated bus protocol. The module power supply has been integrated in the dedicated bus without external wiring.

- DO wiring instructions

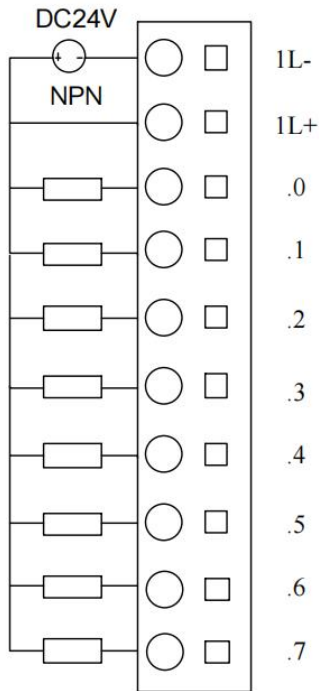

The transistor output of K622S-16DT module only supports NPN output mode, and the left picture shows the external wiring of NPN output. NPN is the signal output line output low level when there is a signal trigger.

Figure 4.1.6-1 K622S-16 DTN module

4.1.7 K633S-06IV

- Power wiring instructions

The module is connected by an extended interface and communicates through the dedicated bus protocol. The module power supply has been integrated in the dedicated bus without external wiring.

- AI wiring instructions

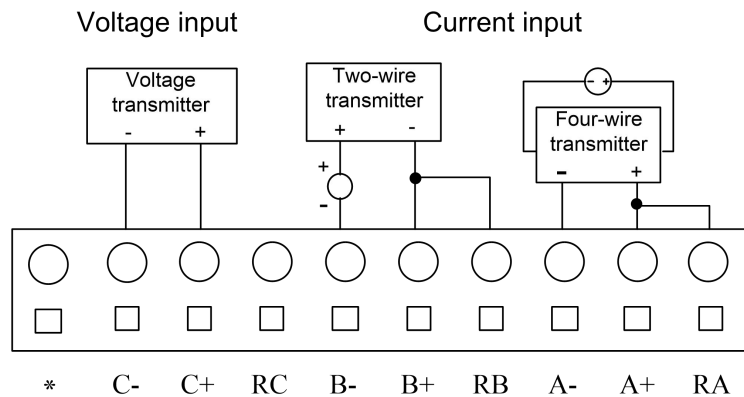

Figure 4.1.7-1: Simog input example

K633S-06IV provides 4 analog input channels to support current and voltage input. The current signal corresponds to the access pins * +, * - and R * (* indicates the channel name: A / B / C / D), and the voltage signal corresponds to the access pins * + and * - (* indicates the channel name: A / B / C / D).

Take the two-line current input as an example, see Group B in the above figure. The transmitter signal + terminal should be connected to the power supply + terminal, the power supply-terminal corresponds to the access channel "B-", and the transmitter signal-terminal is integrated to "B +" and "RB".

Group A in the above figure is for example, the transmitter signal-terminal access channel "A-", the transmitter signal + terminal is parallel connected to "RA" and "A +", and the transmitter power supply input is connected to the external power supply.

Group C in the above figure is an example of voltage input wiring, with the signal plus end corresponding to C +, and the signal-end corresponding to C-.

It is suggested that the user shortconnect the terminals of the unused channel group, and set the corresponding signal form of the group to [0-20mA] or [0-10V] in the programming software, artificially let the pins of this set of channels in the signal acquisition state, and discharge the aggregated charge in the form of short connection to prevent interference and false alarm. The short mode is shown below:

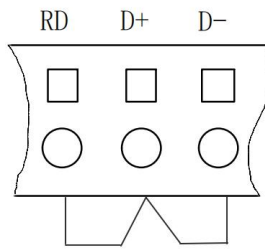

Figure 4.1.7-2: og quantity input short signal

● AI wiring instructions

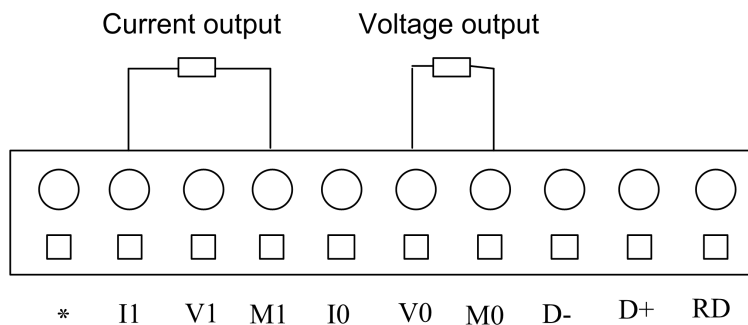

Figure 4.1.7-3: Example of analog output

K633S-06IV provides 2 analog output channels, both supporting both current and voltage output modes. I, V, and M identification correspond to current output, voltage output and common end respectively. The current type output corresponds to M and I pins, and the voltage type output corresponds to M and V pins.

When wiring, we only need to connect the positive end of the analog output (usually marked as +) corresponding to the analog input positive end of the external equipment, and the negative end of the analog output is connected to the negative end of the analog input of the corresponding external equipment.

Group 0 is the voltage output wiring, the voltage output "V0" and the public end "M0" correspond to the analog input positive and negative end connected to the external equipment; the first group is the current output wiring, the current output "I1" and the public end "M1" correspond to the analog input positive and negative end connected to the external equipment.

4.1.8 K631S-04TC

- Power wiring instructions

The module adopts the extended bus connection, and the module power supply has been integrated in the expansion bus.

- TC wiring instructions

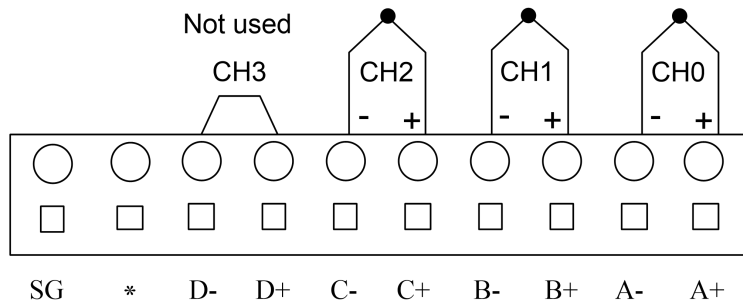

Figure 4.1.8-1 TC wiring description

K631S-04TC module provides 4 channels, "* +", "* -" (* channel group name: A / B / C / D group) corresponding to the positive and negative electrode of the thermocouple. It is suggested that the user short connect the unused channel to avoid mismeasurement or other interference. For the short connection, please refer to CH 3 above.

Also, to avoid interference, ground the FG terminal.

4.1.9 K631S-04RD

- Power wiring instructions

The module adopts the extended bus connection, and the module power supply has been integrated in the expansion bus.

- RTD Wiring Instructions

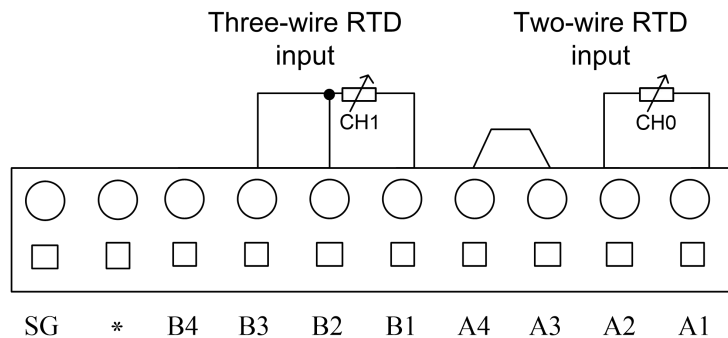

Figure 4.1.9-1 RTD wiring description

K631S-04RD module provides 4 thermocouple input channels, each group has four

terminals: "* 1", "* 2", "* 3", "* 3" and "* 4" (* corresponding channel name: A / B / C / D group).

As shown in the figure above, when connecting the second line thermal resistance, please connect the "1" and "2" feet of the same group to the external thermal resistance, and then shortconnect the "3" and "4" feet of the same group. When connecting to the three-line thermal resistance, connect one end of the thermal resistance to the "4" and "2" feet, and the other end to the "1" feet.

It is recommended that users short connect unused channels to prevent false alarm. Referring to the following below.

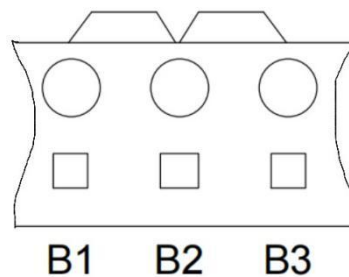

FIG. 4.1.9-1 shows the RTD channel

4.2 Wiring list

4.2.1 K615S-16DT

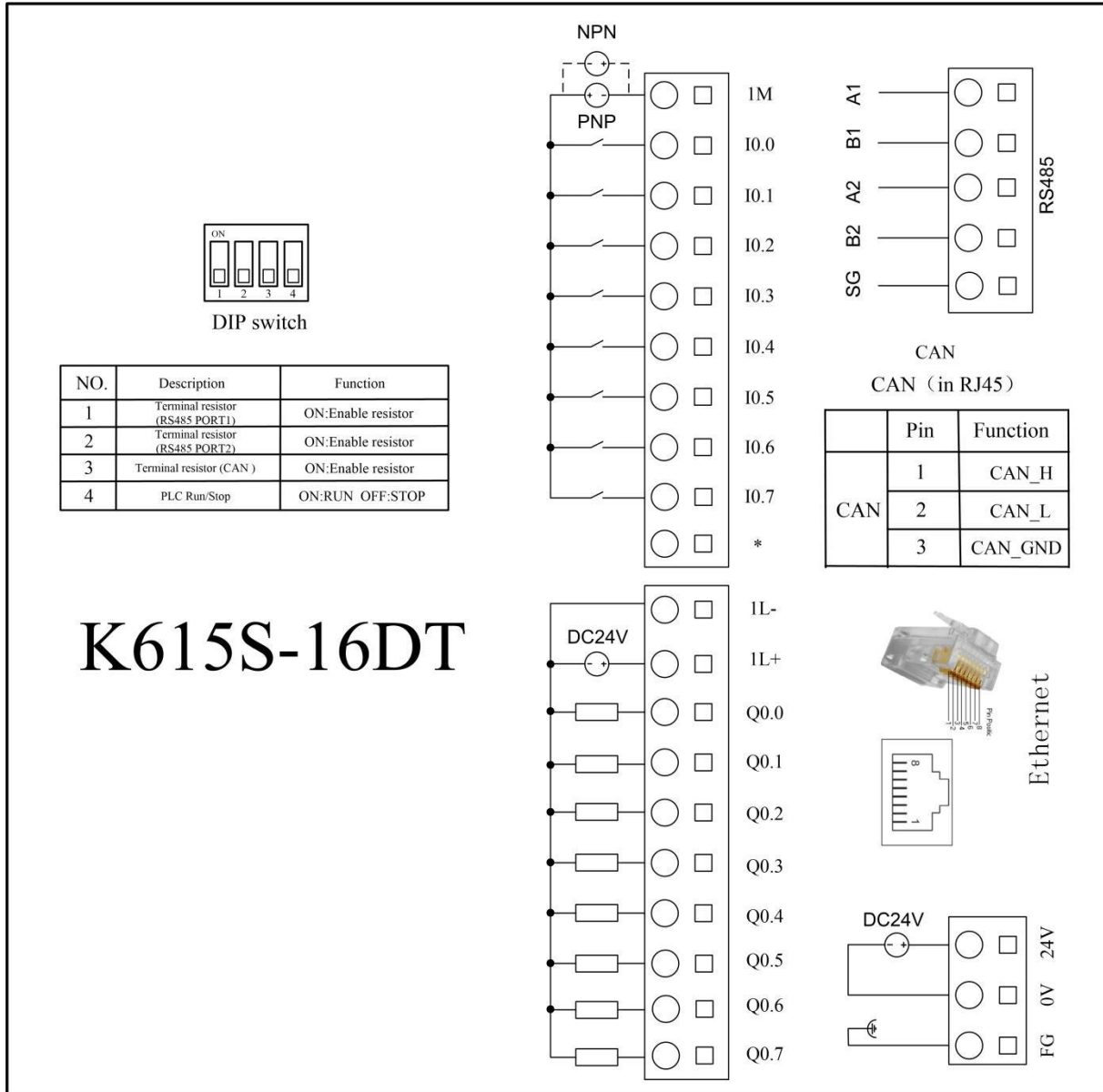

Figure 4.2.1 Wiring diagram of K 615 S-16DT

4.2.2 K621S-16DX

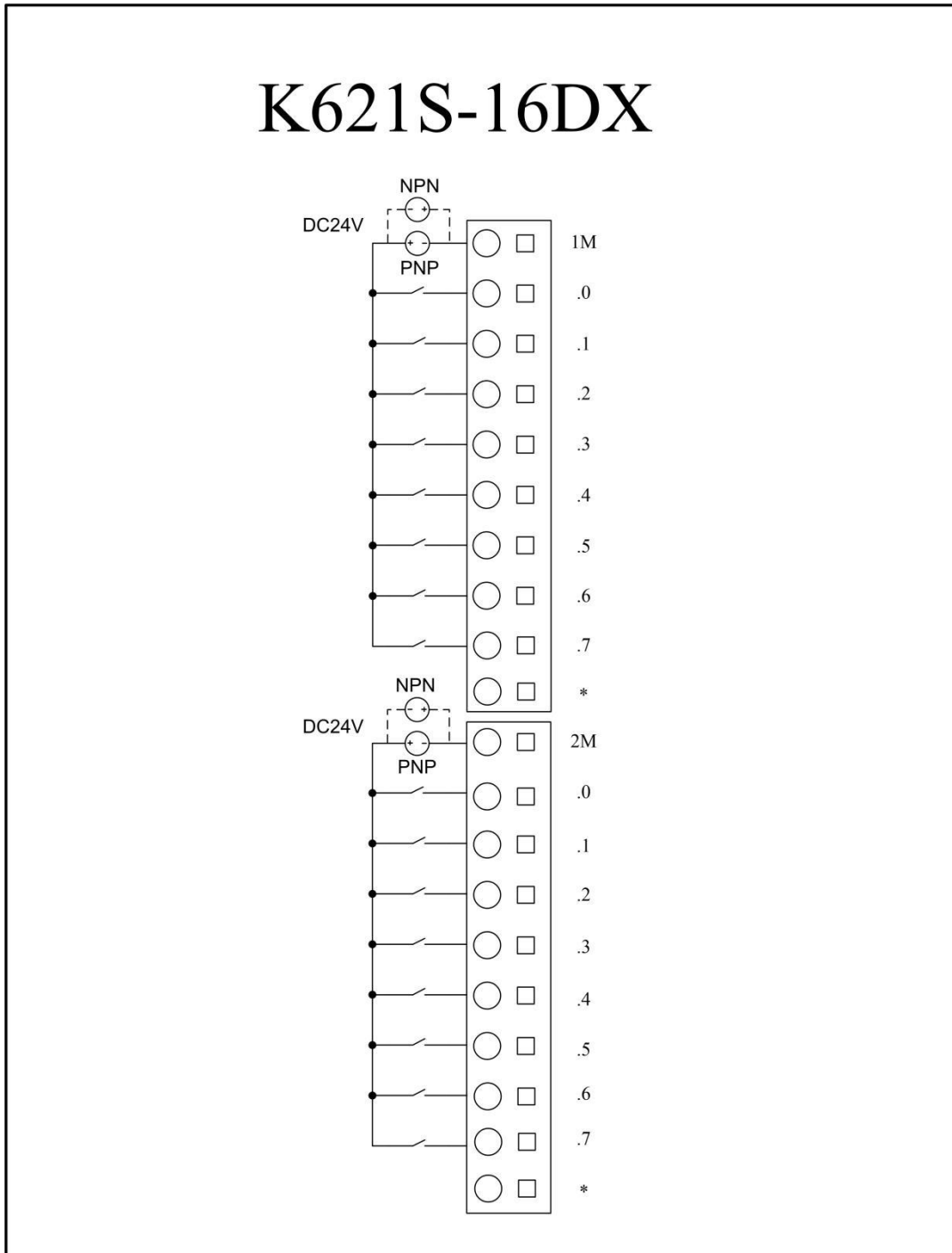

Figure 4.2.2 K621S-16DX wiring diagram

4.2.3 K622S-16DR

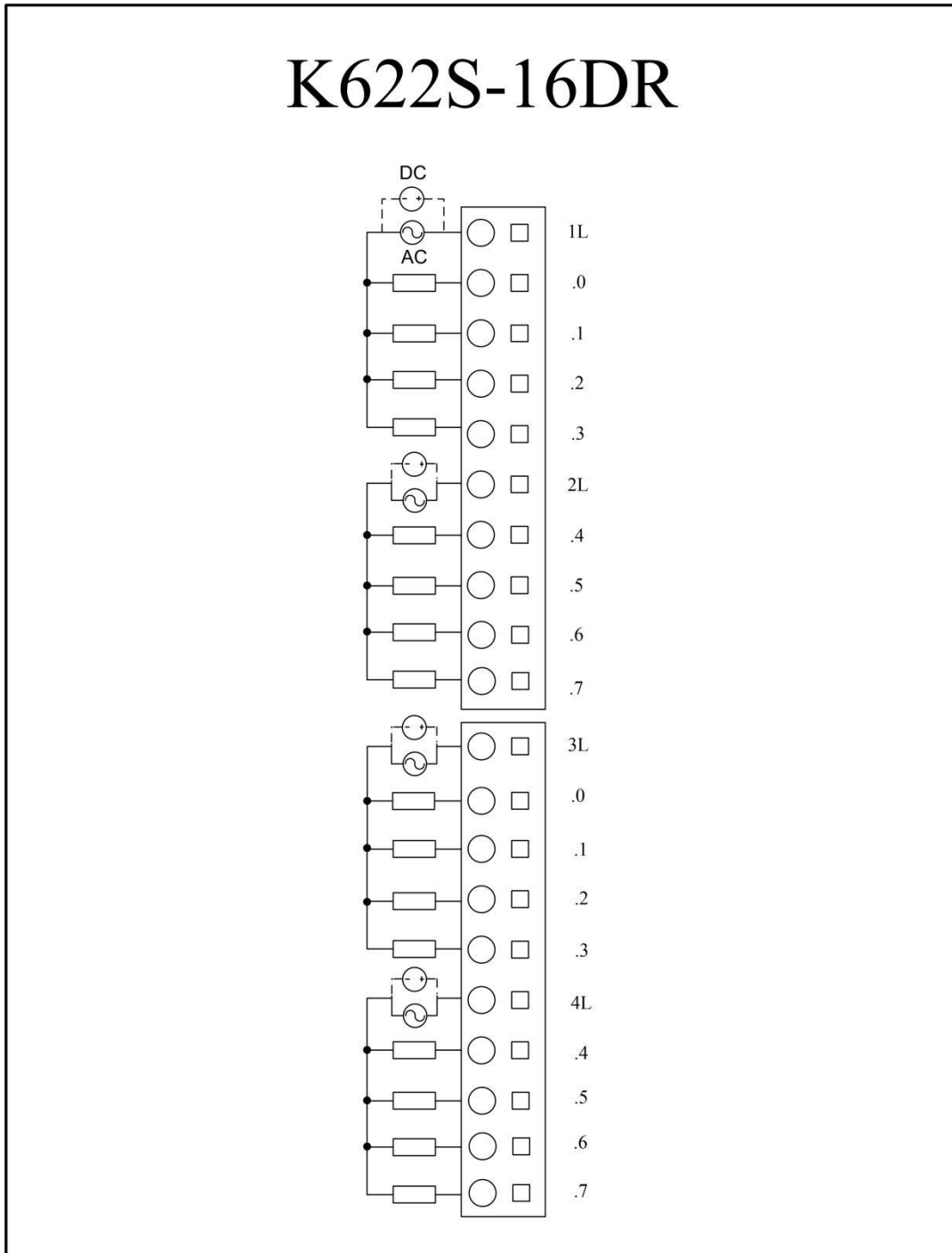

Figure 4.2.3 K622S-16DR wiring diagram

4.2.4 K622S-16DT

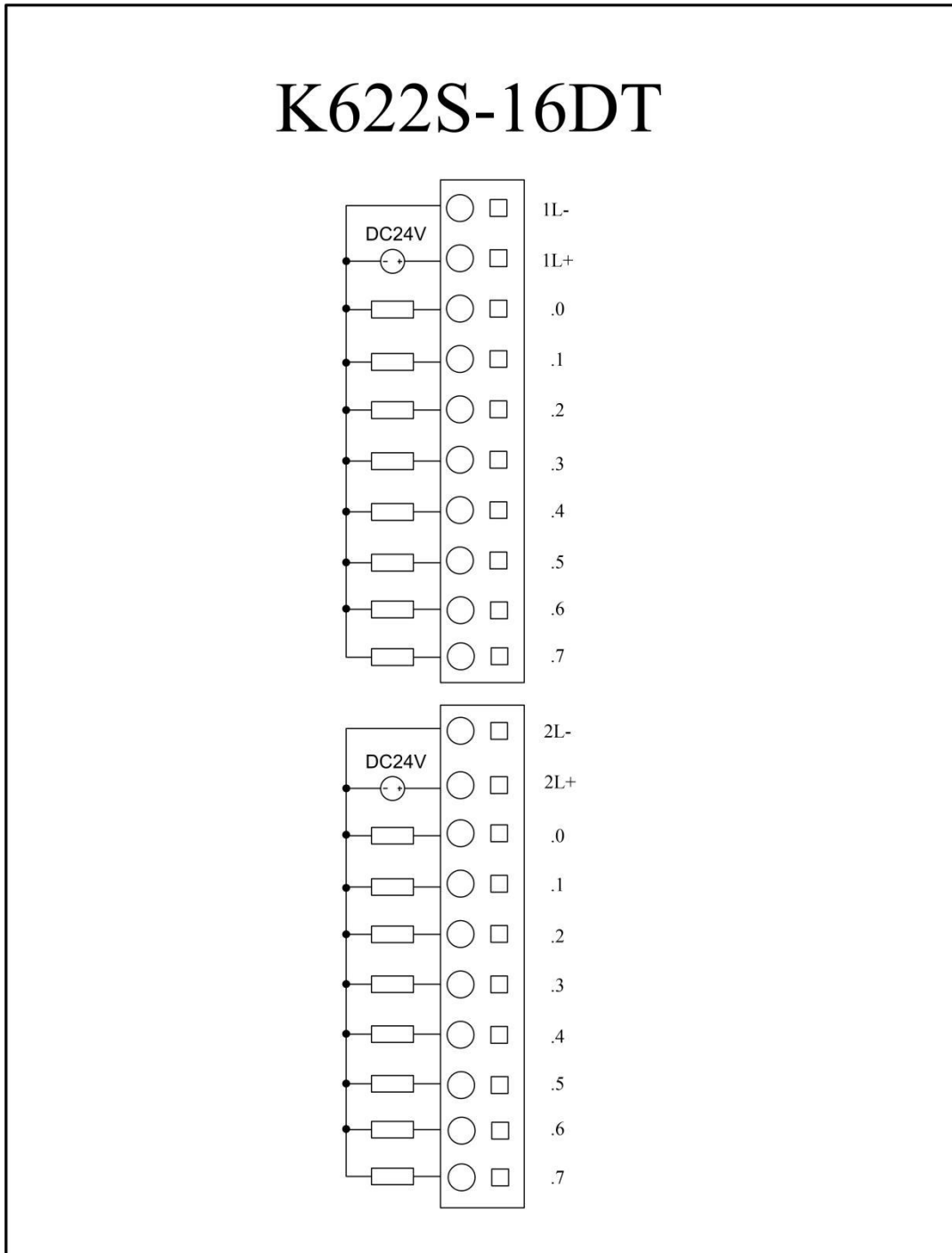

Figure 4.2.4 K622S-16DT wiring diagram

4.2.5 K623S-16DT

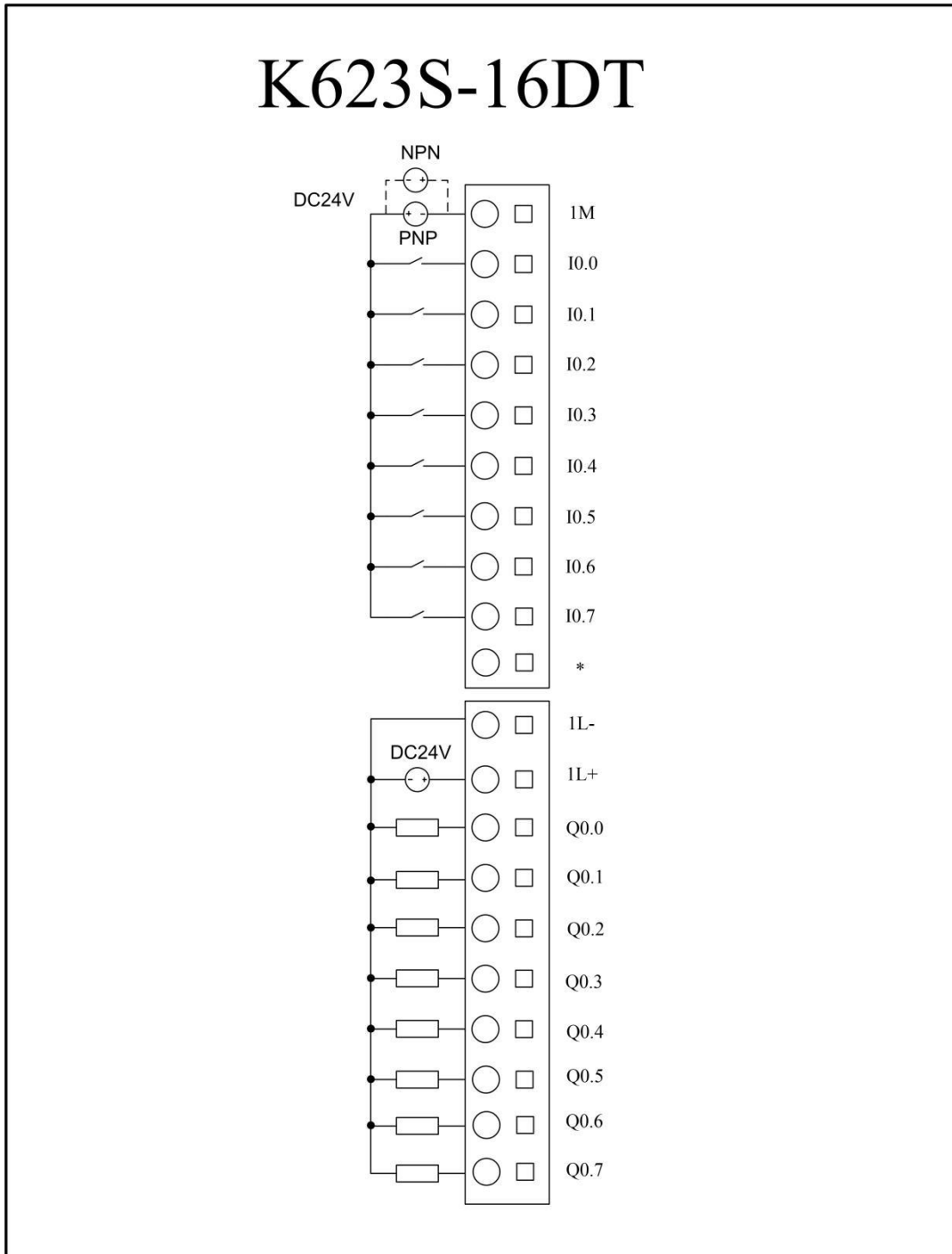

Figure 4.2.5 K623S-16DT wiring diagram

4.2.6 K622S-16DTN

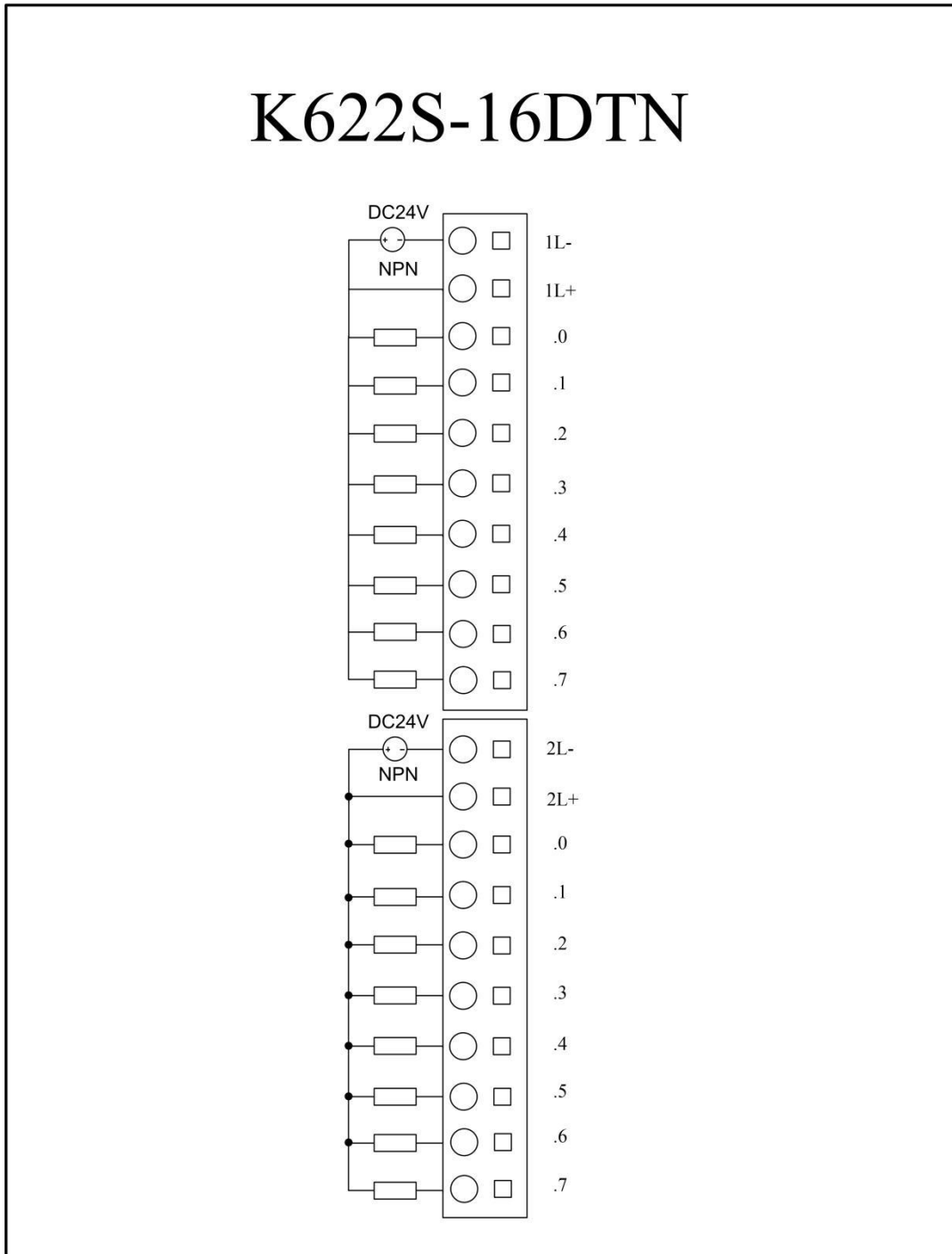

Figure 4.2.6 K 622 DTN S-16

4.2.7 K633S-06IV

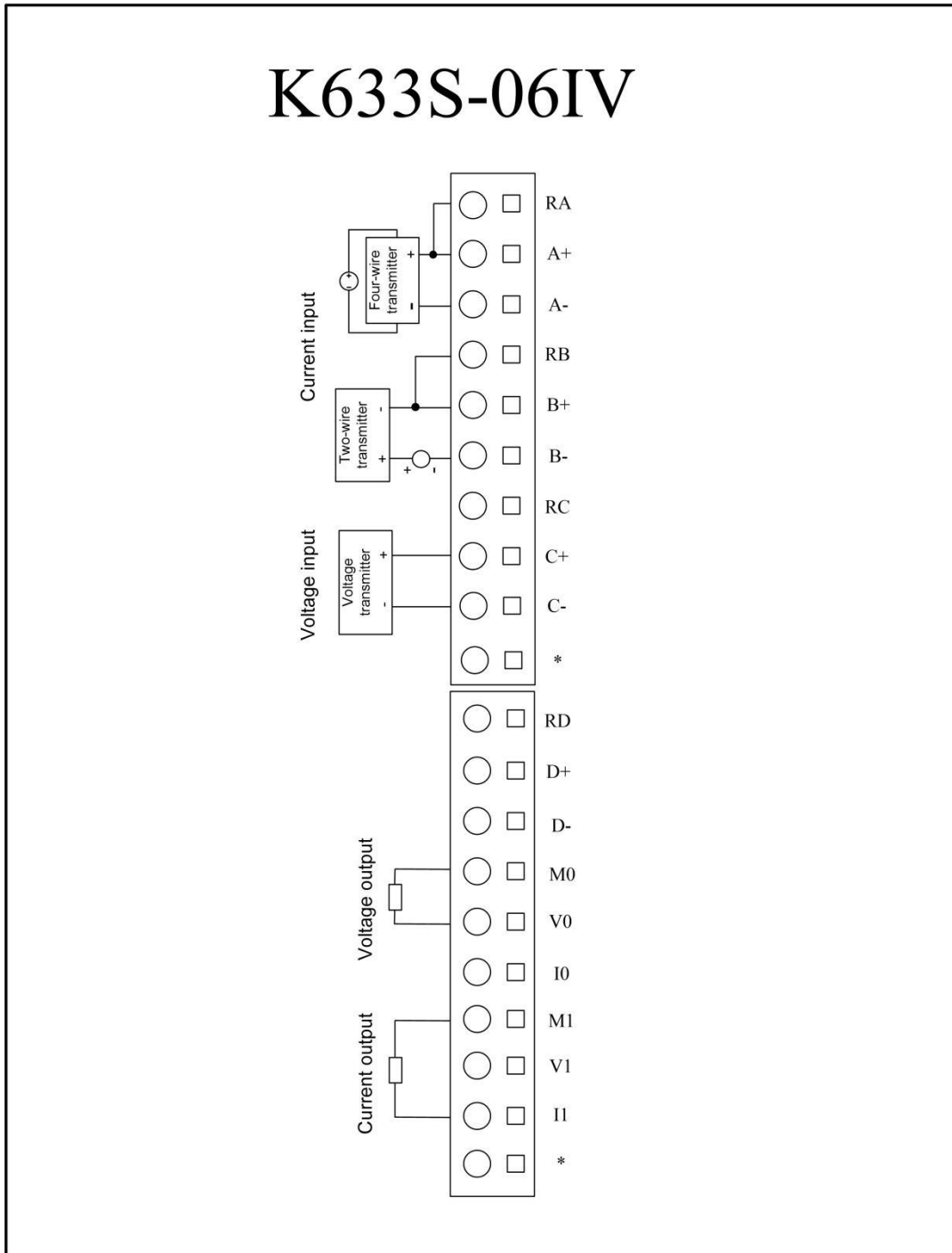

Figure 4.2.7 K633S-06IV wiring diagram

4.2.8 K631S-04TC

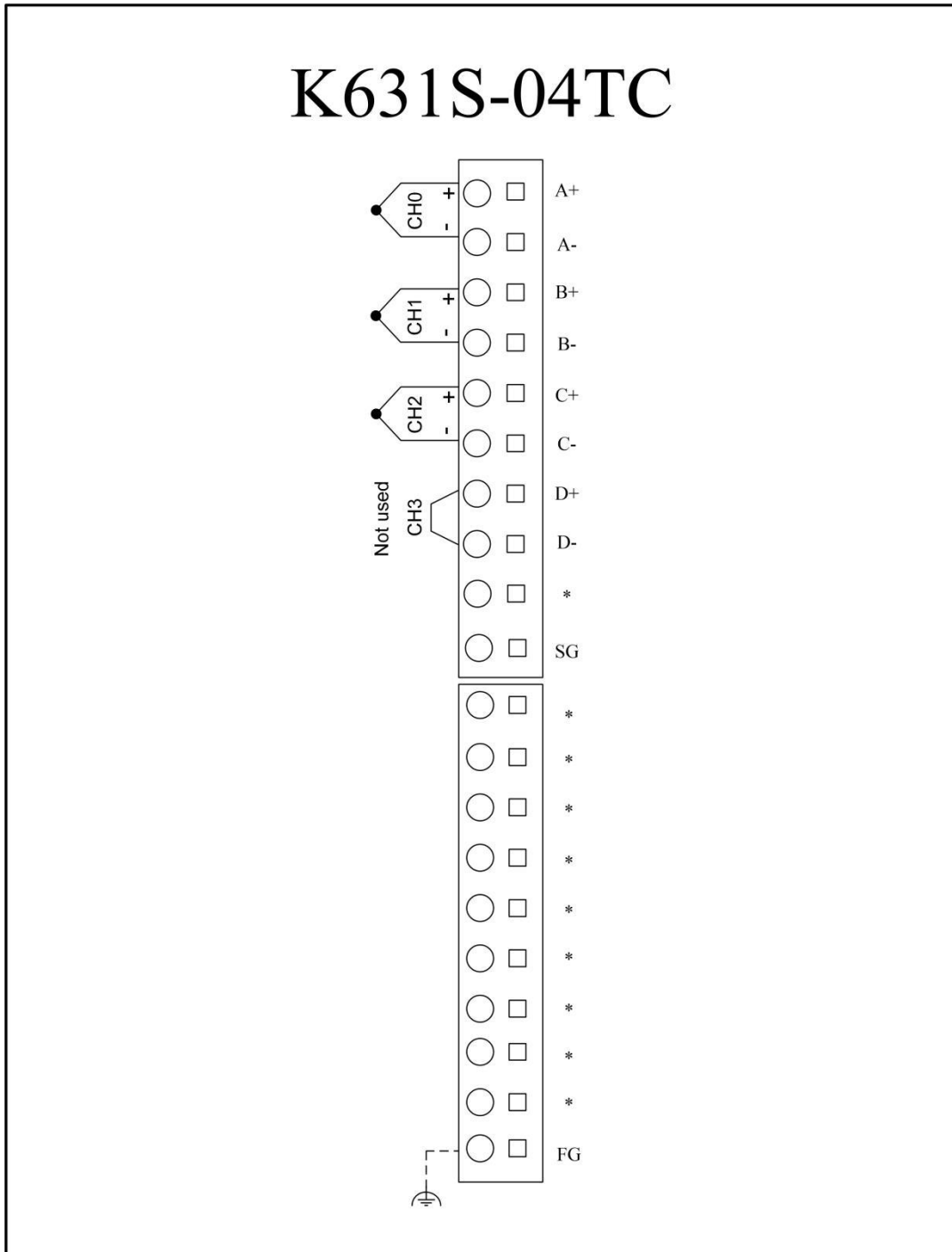

Figure 4.2.8 K631S-04TC wiring diagram

4.2.9 K631S-04RD

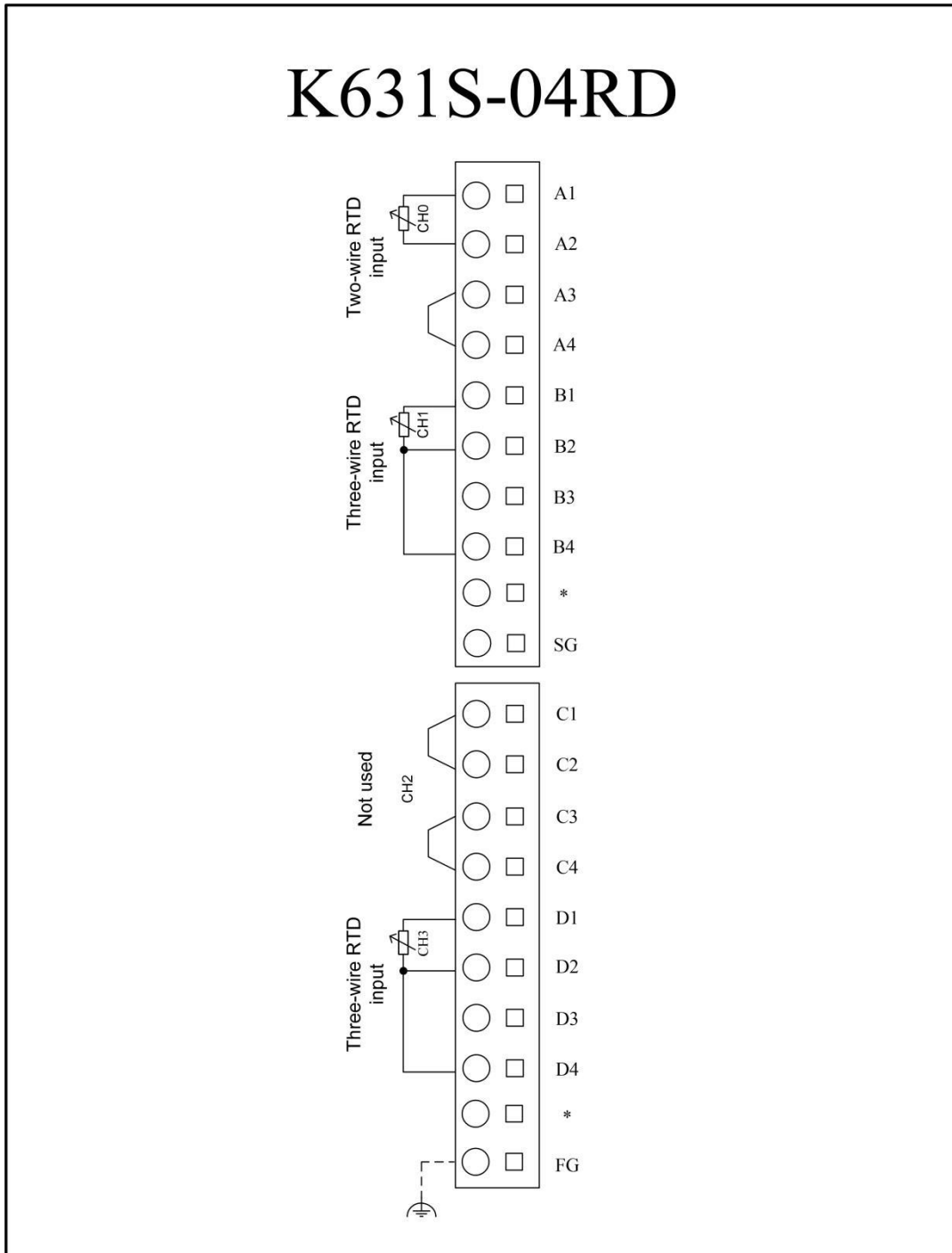

Figure 4.2.9 K631S-04RD wiring

4.3 Dimension description

4.3.1 The CPU module

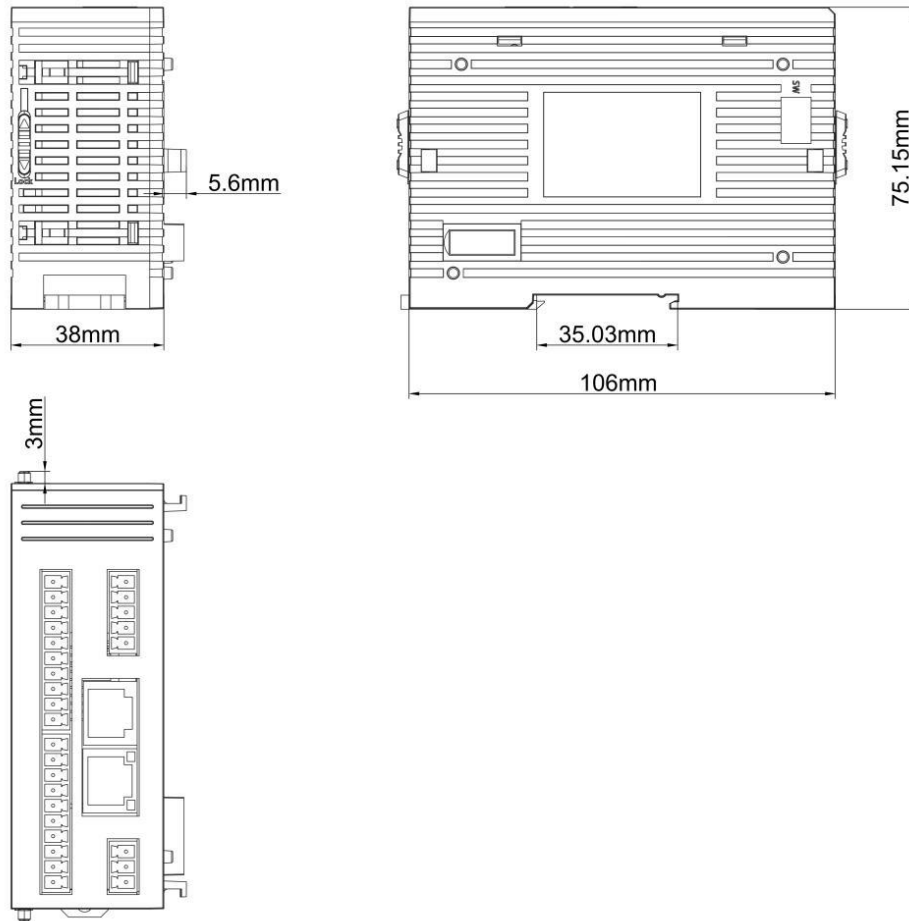

Figure 4.2.2 K621S-16DX wiring diagram

The above figure applies to the K6S series CPU K615S-16DT.

4.3.2 Extended expansion module

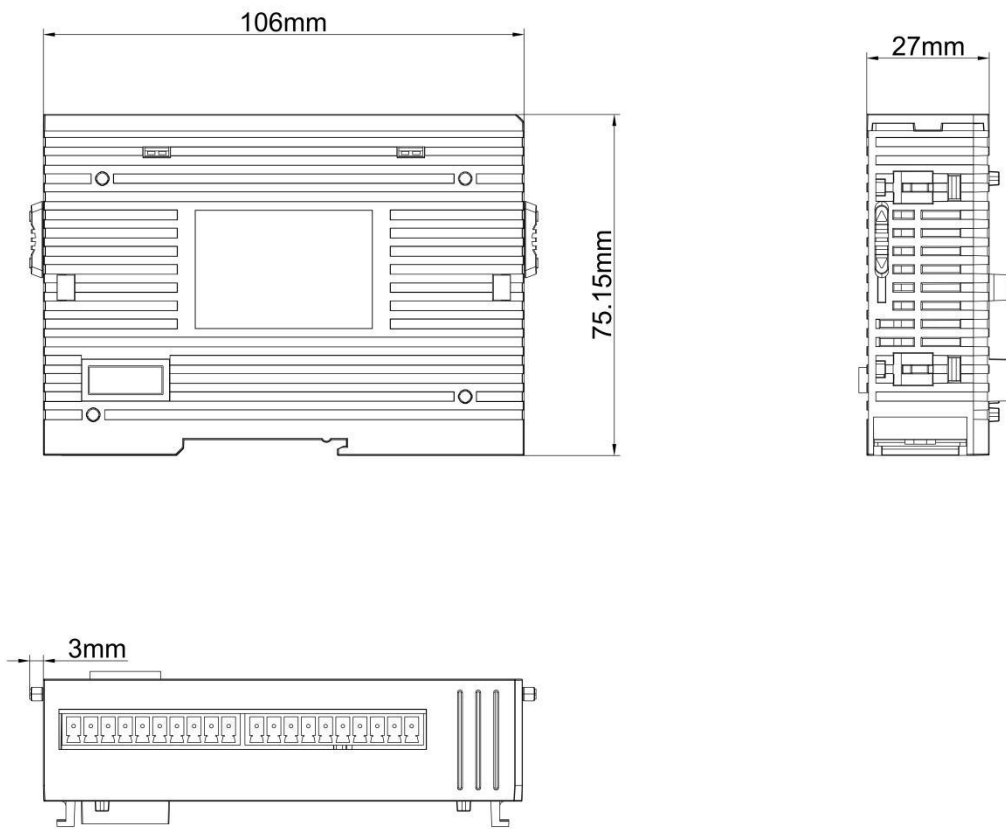

Figure 4.3.2 Expansion module dimension drawing

The figure above applies to all the extended modules of the K6S series.

5. Installation criteria

5.1 CPU module connection extension mode

The K6S series adopts the physical connection mode of the expanded port needle row and socket, and the extended connection can be completed without external wiring.

In the actual connection, with the CPU module as the starting point, the extension bus physically leads from the right side of the CPU module to the right module to the right of the first extension module to the extension interface socket on the left side of the first extension module to the right side of the CPU extension module; to the second extension module to the right side of the right side of the first extension module, K615S-16DT supports the maximum connection of 16 extension modules. After the expansion module is connected, pull the lock above the module and lock it. When disassembly, release the lock and then strip the module. As shown in the figure below:

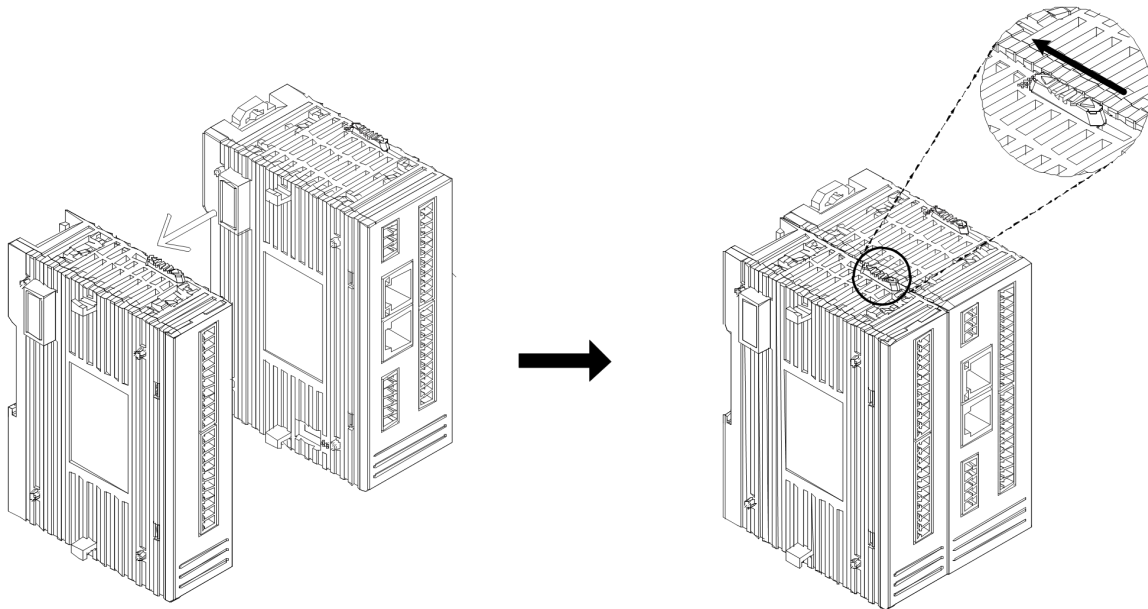

Figure 5.1-1 CPU extension connection method

⚠ pay attention to:

- (1) When the expansion port of the docking module needs to be smoothly aligned, and

should not be pushed by brute force, otherwise the pin of the expansion port may be bent or broken, and the module cannot be normally connected to or even used normally;

(2) When taking off the extension, pay attention to first pull the lock above the module and then remove, not brute force leverage or other ways to pull.



Figure 5.1-2 Physical diagram of CPU extended connection

5.2 Install with the DIN guide rail

5.2.1 The DIN guide rail standard

DIN is the German industrial standard, the use of guide rail is a way of installation of industrial electrical components, the installation of electrical components supporting this standard can be easily stuck on the guide rail without the need to fix with screws, maintenance is also very convenient. The standard width is 35mm, mostly see the following two specifications:

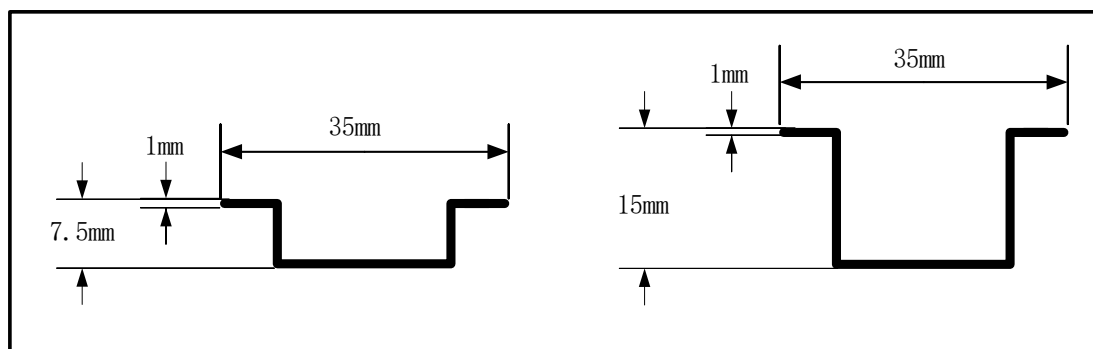

Figure 5.2-1 Common standard of DIN guide rail



Figure 5.2-2 Physical drawing of the DIN guide rail

5.2.2 Installation / removal steps of the guide rail

The installation steps are performed as follows:

1. Install the standard 35mm wide DIN guide rail first. If installed horizontally, have at least 60mm above and below the rail, and at least 60mm on the left and right of the rail.
2. Pull out the guide rail slider of the module down (loose down and locked up), card the upper end of the module guide rail connection to the edge of the guide rail, and card the module into the guide rail down, as shown in the figure below:

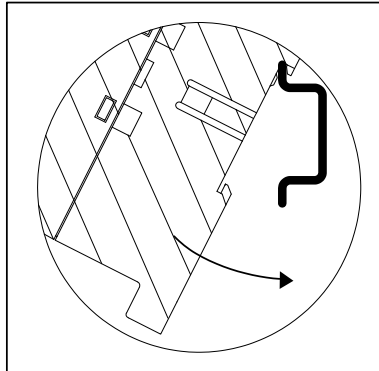

Figure 5.2-3 Installation steps of DIN guide rail

3. Install all modules correctly on the guide rail in the above method, move all modules to a fixed place, connect the expansion interface of the module horizontally, and dial the buckle above the module to lock in pairs. Finally, push the guide rail slide of each module up to the locking position to complete the installation. The installation effect is shown below:



Figure 5.2-4 Rail slide lock (left) / release (right)



Figure 5.2-5 Effect diagram of DIN guide rail

⚠ pay attention to:

- (1) To ensure good ventilation, leave at least 60mm of space on and below the module during installation, and have a depth of at least 100mm.
- (2) During vertical installation, users should note that the maximum working

environment temperature of the module should be reduced by 10°C.

(3) When the guide rail is installed, you need to open the buckle and install the module on the guide rail one by one before extending the connection, otherwise the extension interface may be damaged.

Disassemble a module as follows:

1. First pull the guide rail slide of all modules down and release the lock;
2. Pull the upper buckle of the module and the module on both sides of the module forward and release the module connection;
3. Take the modules to be disassembled as the benchmark, push other modules to both sides and switch the expansion connection with the target module;
4. Pull the target module from the bottom up as shown below:

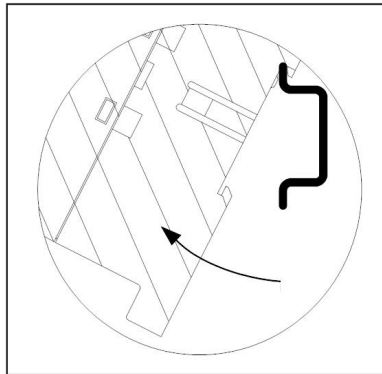

Figure 5.2-5 Disassembly diagram of the DIN guide rail

5. After completing the disassembly of the target module, reassemble the remaining modules according to the assembly steps.

5.3 Installation space requirements

The K6S series is designed for natural convection cooling. To ensure adequate cooling, a minimum clearance of 60mm must be cleared above and below the equipment. In addition, a depth of at least 40mm shall be allowed between the front end of the module and the inner wall of the cabinet.

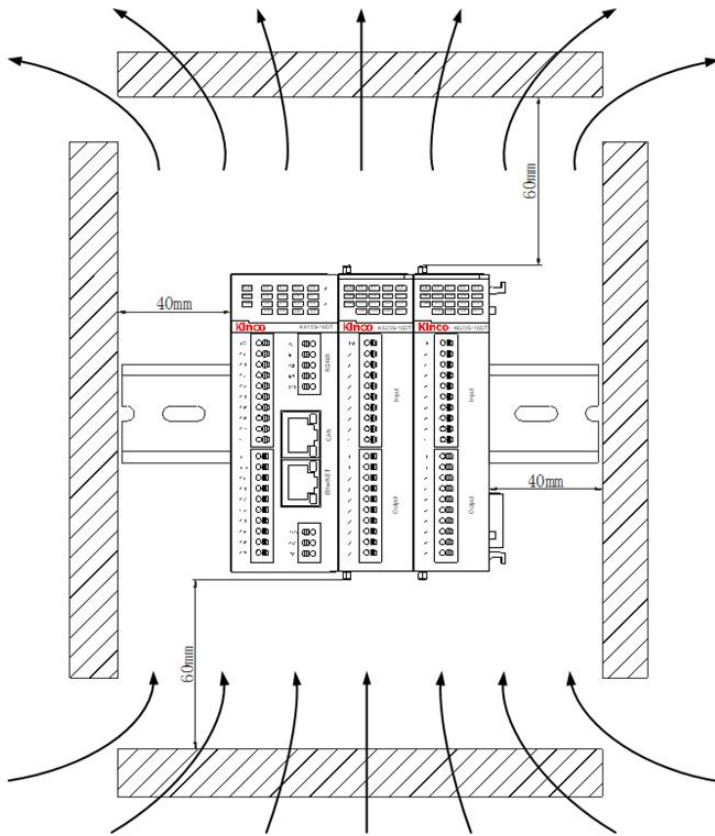

Figure 5.3-1, Installation space requirements

6 Use entry

KincoBuilder Is the upper programming software of K series PLC of Step Company. The programming environment meets IEC61131-3 standard and helps users with efficient program development. The installation process and installation configuration requirements are omitted here, and only a brief introduction is made with the user introduction. For more specific software use instructions, please refer to the software use manual.

6.1 Introduction to the KincoBuilder software interface

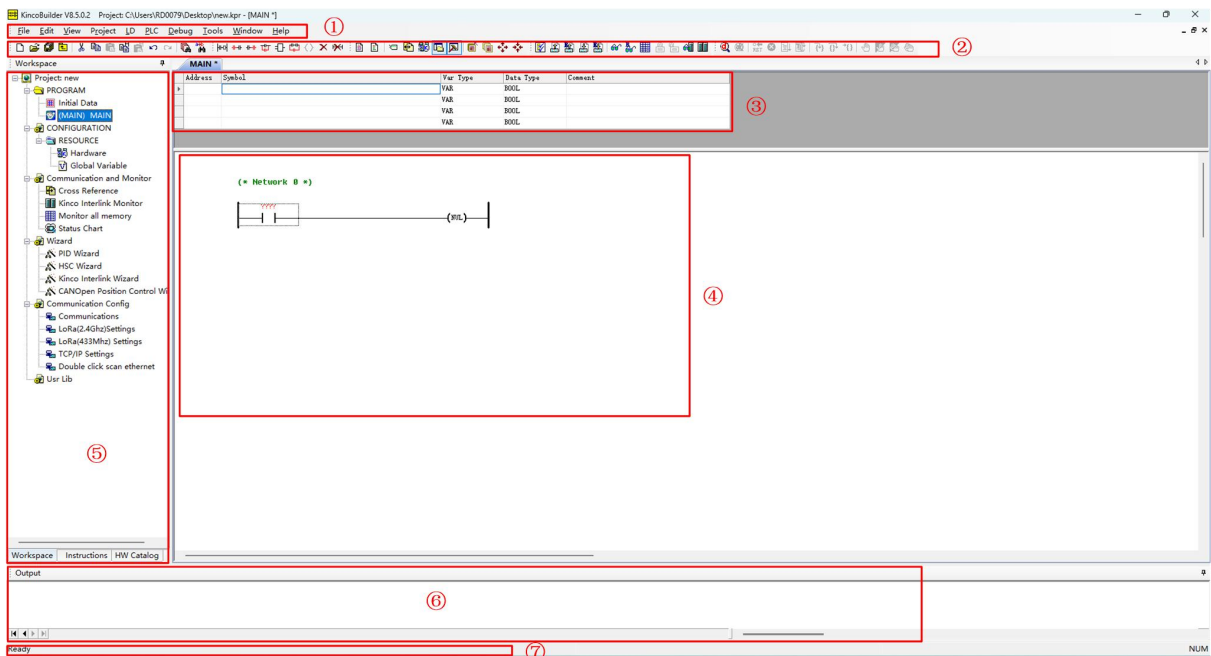



Figure 6.1-1 Brief description of the KincoBuilder interface

order number	project	description
①	menu bar	The menu contains all the operation commands of the KincoBuilder software.
②	tool bar	The toolbar contains some action commands that users use more frequently.
③	Variable Definition Zone	Users can make a variable declaration here.
④	Program editing area	Here is the user programming area, divided into LD editor and IL editor.
⑤	Project management and configuration	The Engineering Manager is one of the main windows in the interface, showing the current moment visually in the form of a tree list

	area	All components of the project, including program, hardware configuration, variable status table, global variable table, etc. Users can manage, operate, and maintain the currently open project in this window. Each tree node of the Project Manager supports right-click. Right-clicking a node brings the corresponding menu up.
⑥	Information output window	To display the various prompt information of the KincoBuilder software. The Compile Information window displays the use of the latest compilation of the household, and the "General Information" window shows hints for some recent operations.
⑦	situation display	The status bar provides the current status information of the software and the prompt information for the operation commands.

KincoBuilder In the toolbar, some common function areas, convenient for users to use quickly, users can hover the mouse on the corresponding icon to view the thumbnail of the corresponding function and the corresponding shortcut key operation information. For a more specific software introduction, please refer to the relevant application manual.

6.2 KincoBuilder new construction project

KincoBuilder A new project has two paths, first open the software by double-clicking the KincoBuilder icon. 

The following figure shows the initial interface after opening the software:

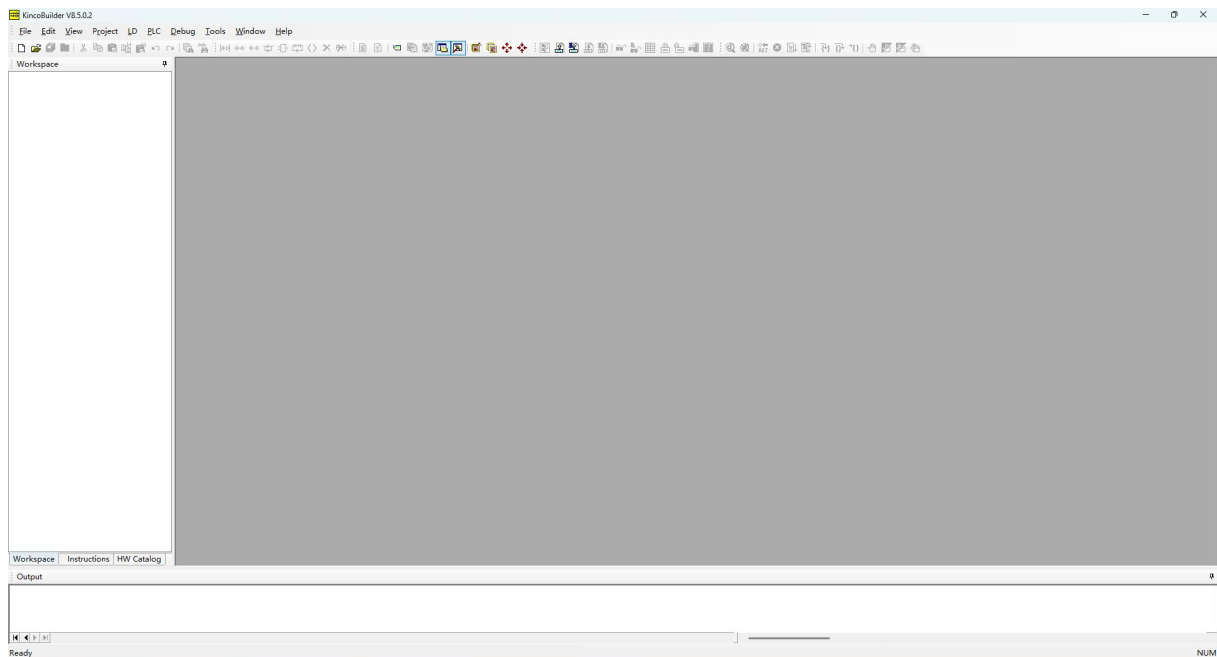

Figure 6.2-1 KincoBuilder Initial Interface

Users can create a new project by: [menu bar] [file] [New Project (N)] or a new project

by directly clicking the [New Project] button on the toolbar, as shown in the following figure.

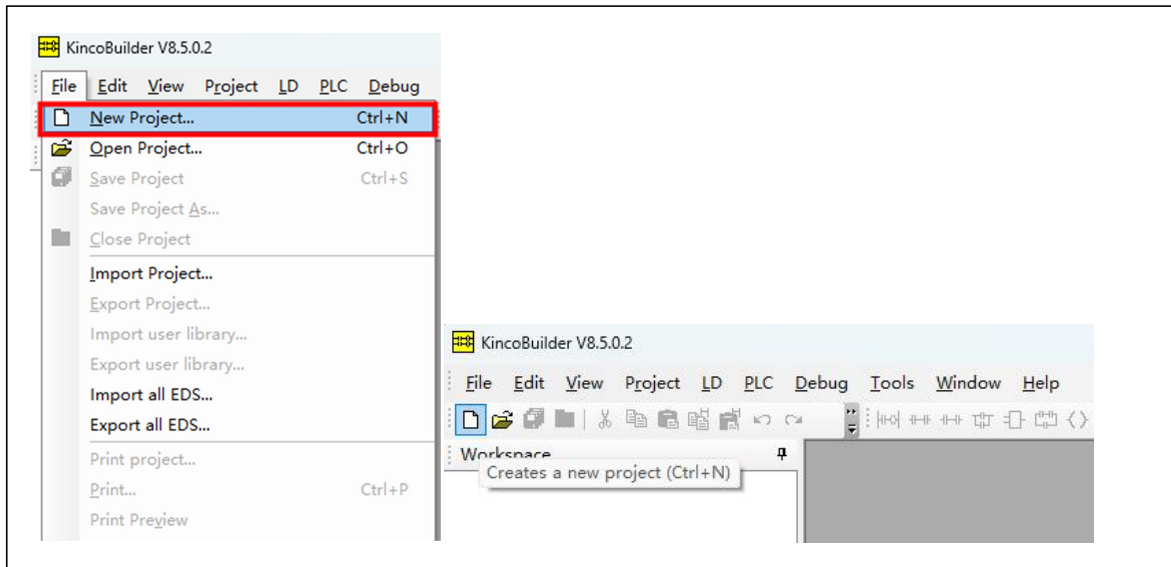

Figure 6.2-2, new construction path

Then select the project save location in the [New Project] dialog box, modify the project name, and click "Save" to complete the creation.

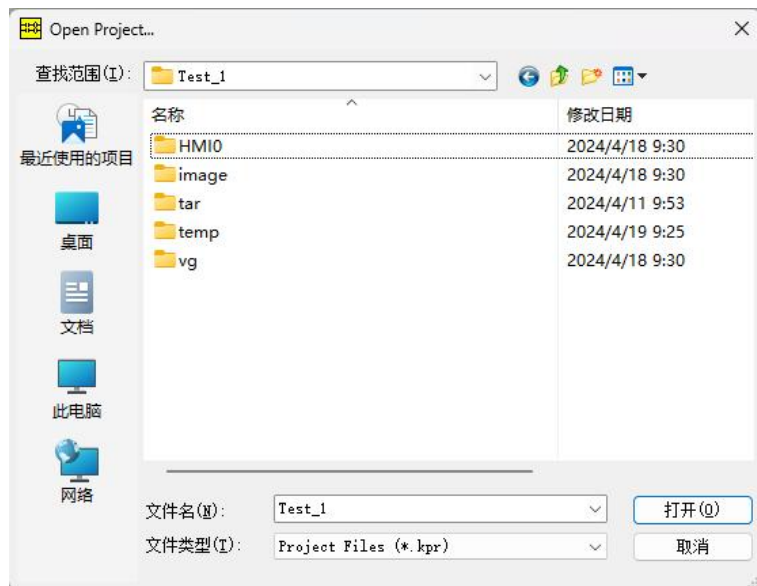

Figure 6.2-3 New Project dialog box

6.3 KincoBuilder hardware configuration

6.3.1 KincoBuilder Configure the CPU

After the new project, the program will default the CPU configuration for a certain model, the user needs to modify according to the actual hardware model, the default

configuration model of the new project can also be opened through the menu bar [tool] [software Settings], in the [default CPU model] in the drop-down menu, click [application] to save.

Take the K615S-16DT as an example, the CPU configuration method is introduced here. KincoBuilder In, the CPU is configured in [PLC Hardware Configuration]. Users can find [PLC Hardware Configuration] in the left device tree, double-click Open, or click the [Open Hardware Configuration page] button on the menu bar.

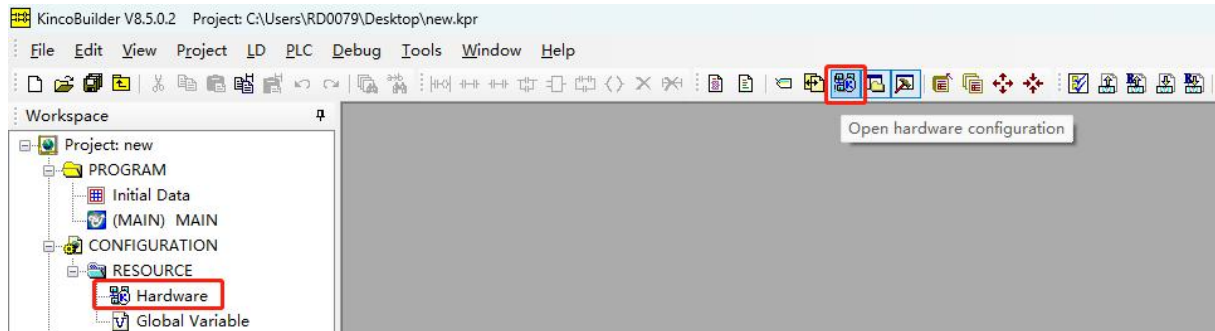

Figure 6.3-1 Open the hardware configuration interface

Because the actual CPU model is not consistent with the default configuration of the project, the configuration of the project should be modified. After entering the [PLC Hardware Configuration] interface, the first one in the hardware configuration list is the CPU configuration information. Right-click the module name and click the displayed [Delete module] prompt button to delete the configured module. Then open the [PLC Module List] in the left device tree, and find "K615S-16DT". Double-click "K615S-16DT" to automatically add to the CPU configuration bar of the current project.

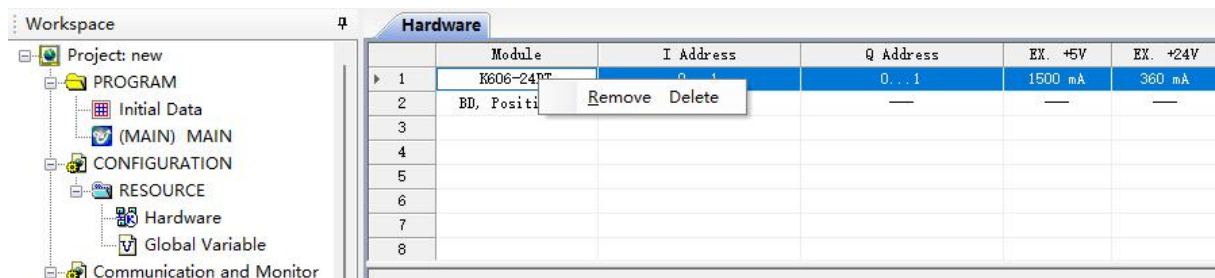

Figure 6.3-2 Delete the unfit CPU

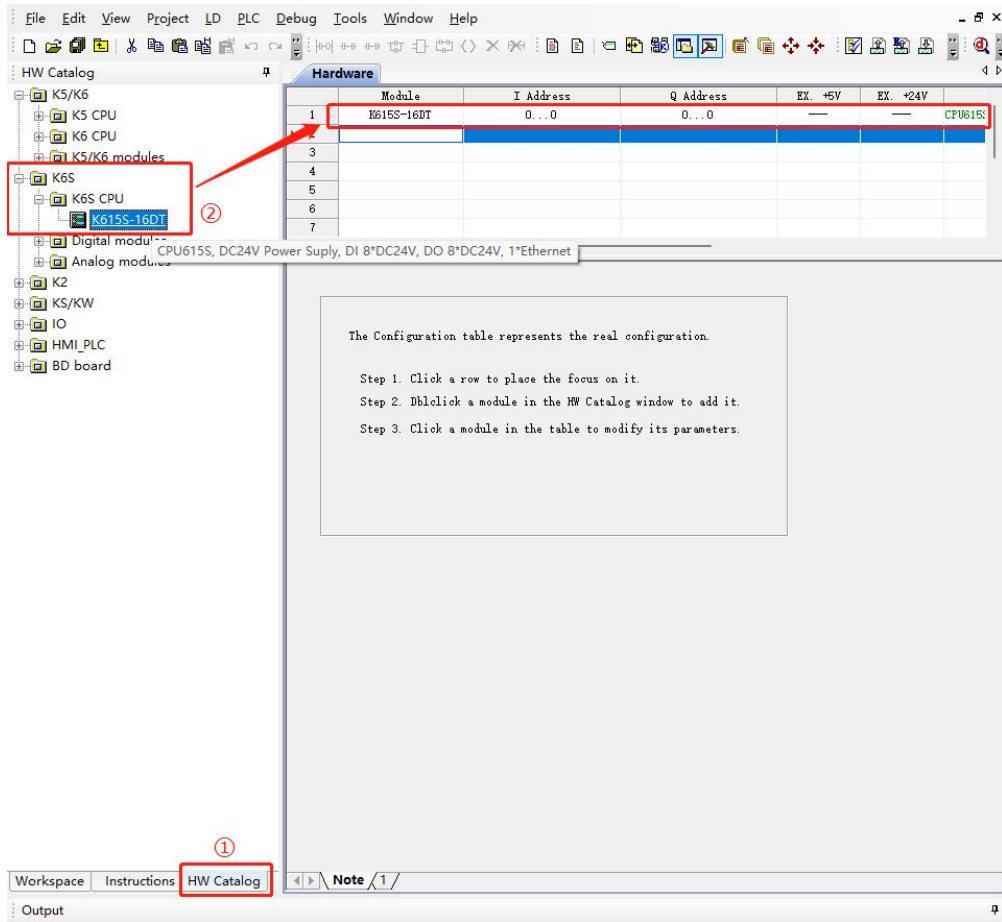

Figure 6.3-3 Configuration K615S-16DT

Select the model in the [Hardware Configuration] interface, and the corresponding configuration interface can be opened. The following figure shows the configuration interface opened when K615S-16DT is selected. I / O configuration, communication configuration, data retention configuration, CANopen master station configuration and so on can be performed in this interface. Refer to the software usage guide for a more detailed configuration tutorial.

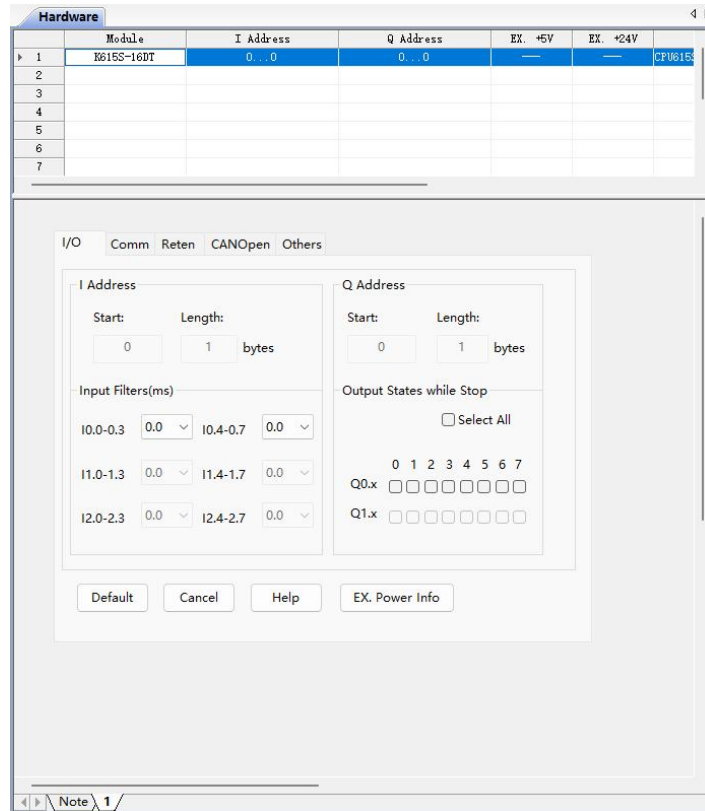

Figure 6.3-4 K615S-16DT configuration interface

6.3.1 KincoBuilder Configure the extension module

After the correct connection of the expansion module is physically completed, the expansion function needs to be configured through the KincoBuilder software before it can be really used. The specific steps to enable the expansion module on the software: [hardware configuration] [PLC module list] [K6S series], select K615S-16DT and double click to add.

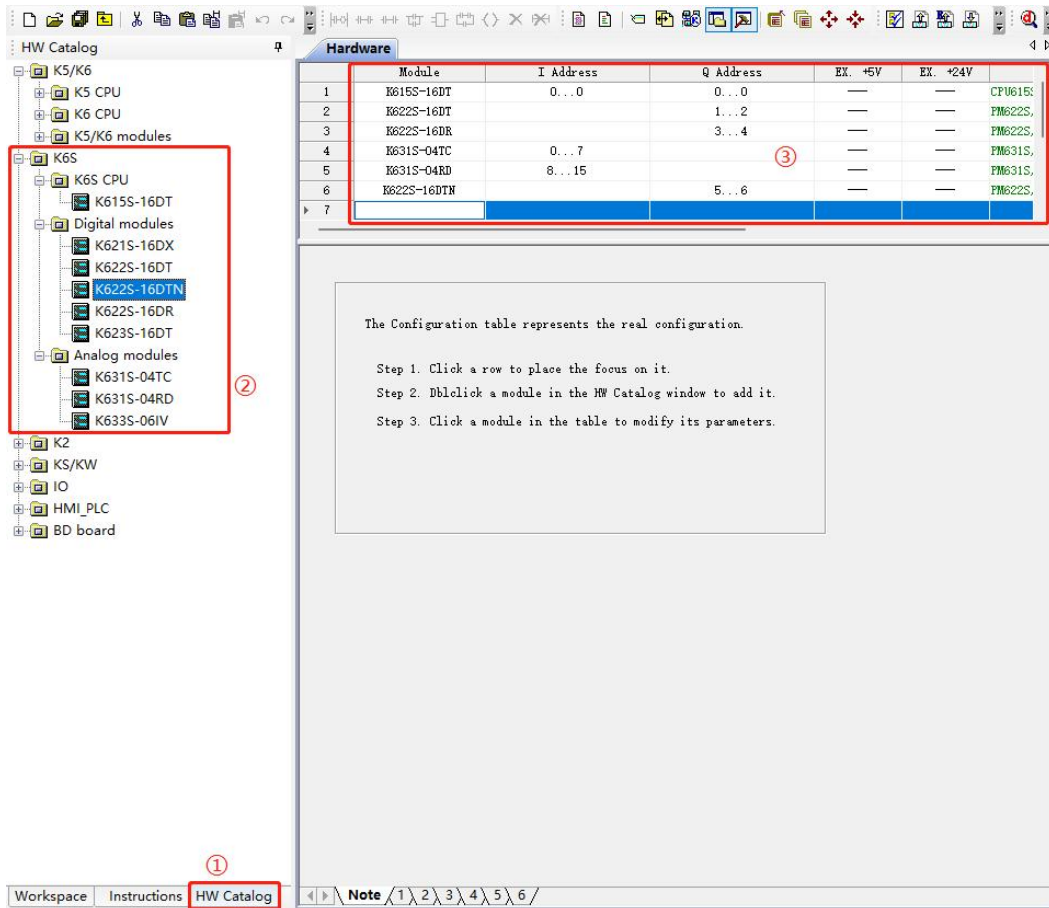

Figure 6.3-1 Extension module configuration operation instructions

If you need to set the expanded input and output, select the corresponding module model to open the relevant setting interface.

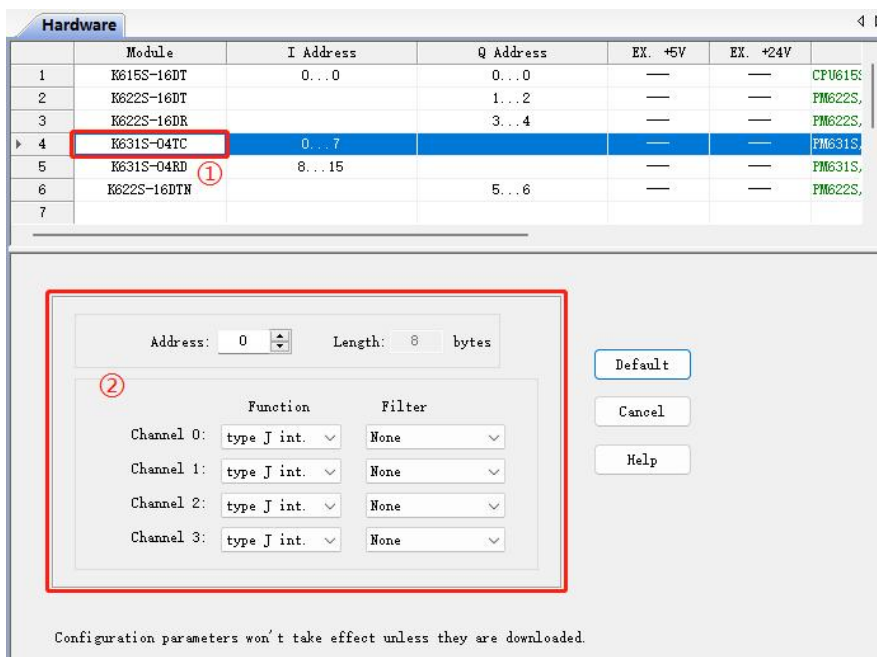

Figure 6.3-2 The extended module parameter configuration

⚠ Note: In the hardware configuration of KincoBuilder, the order of the expansion module should be added in accordance with the actual hardware connection order (from left to right), otherwise the PLC error will be caused.

6.4 Simple description of programming

6.4.1 Online help

More detailed instructions are built in the KincoBuilder software. Users can click [Help] [Help Topic (H)] to open the online help interface in the toolbar. The help interface can help users quickly find programming instructions.

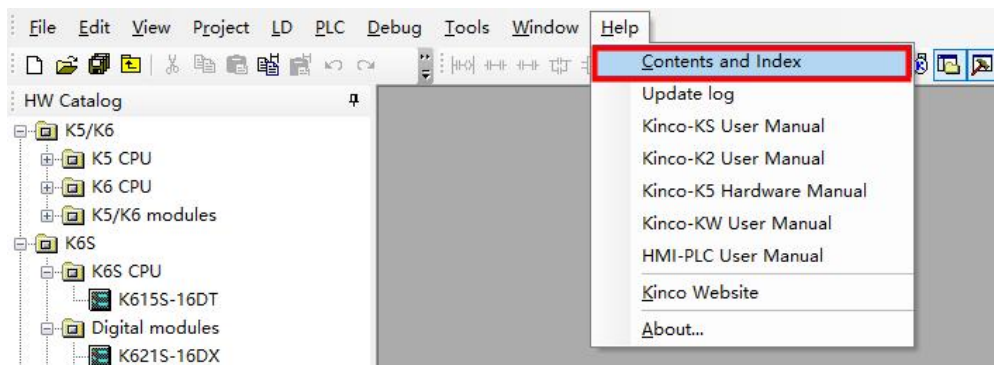

Figure 6.4-1 The User Manual

Users can find detailed instructions in the left navigation bar of the interface to search the directory, keyword index and search. It also supports the found information to be added to the favorites for the next view.

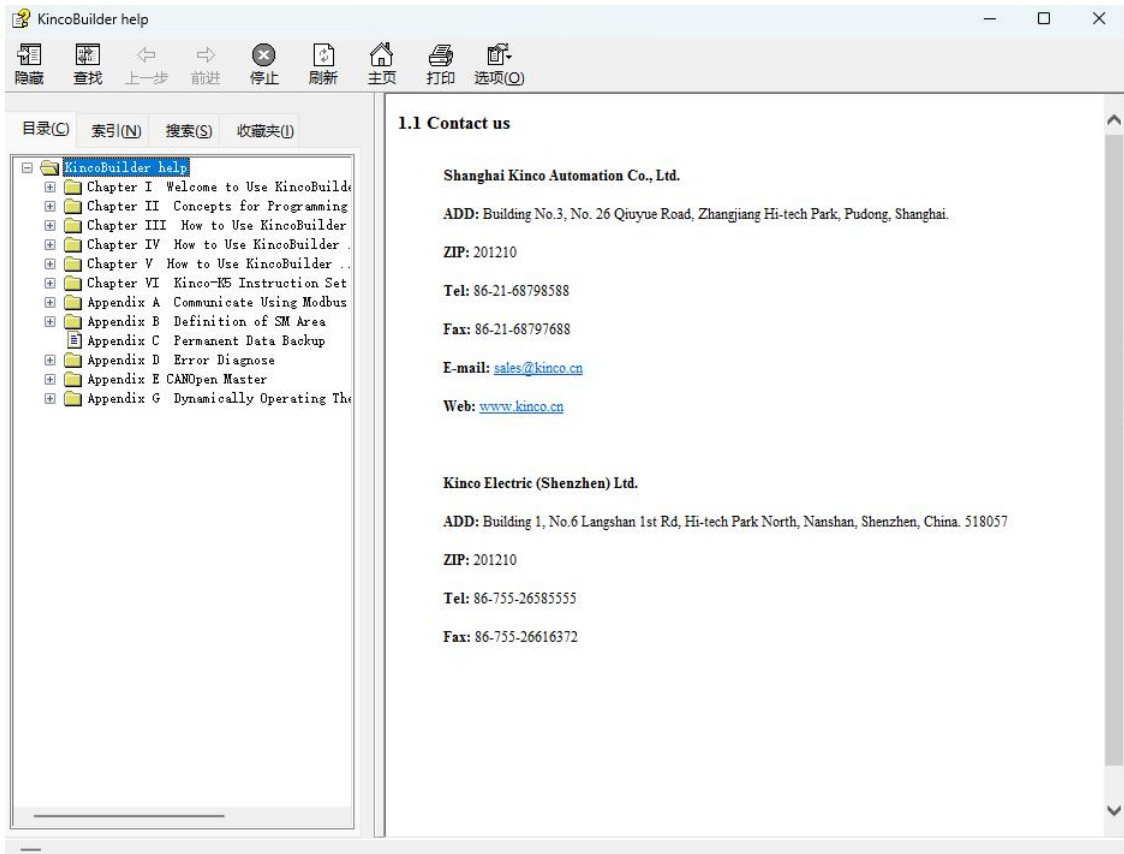

Figure 6.4-2, with the online help interface

6.4.2 KincoBuilder Programming language

KincoBuilder Support for IL language and LD language, in the software can be converted through the toolbar [engineering].

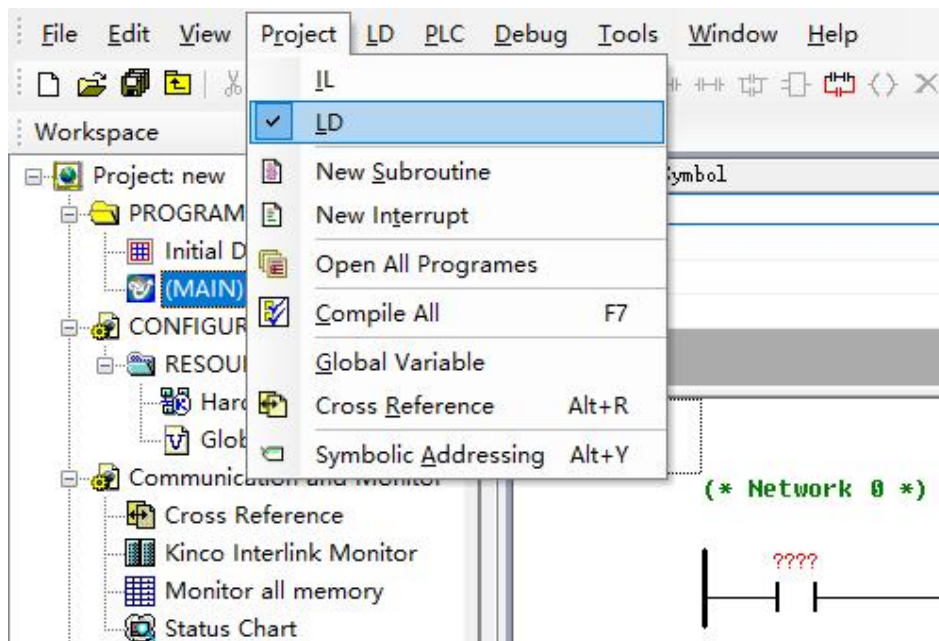
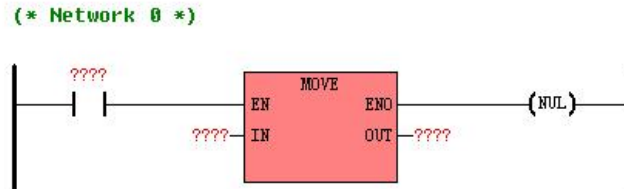

Figure 6.4-3, Programming language setting

6.4.3 Programming instructions

The usage of specific programming instructions is not introduced here, but only introduces how to quickly obtain the usage of programming instructions:

1. Click the corresponding instruction and press F1. KincoBuilder will open the online help and automatically jump to the description page of the instruction.



Click the command and press F1.

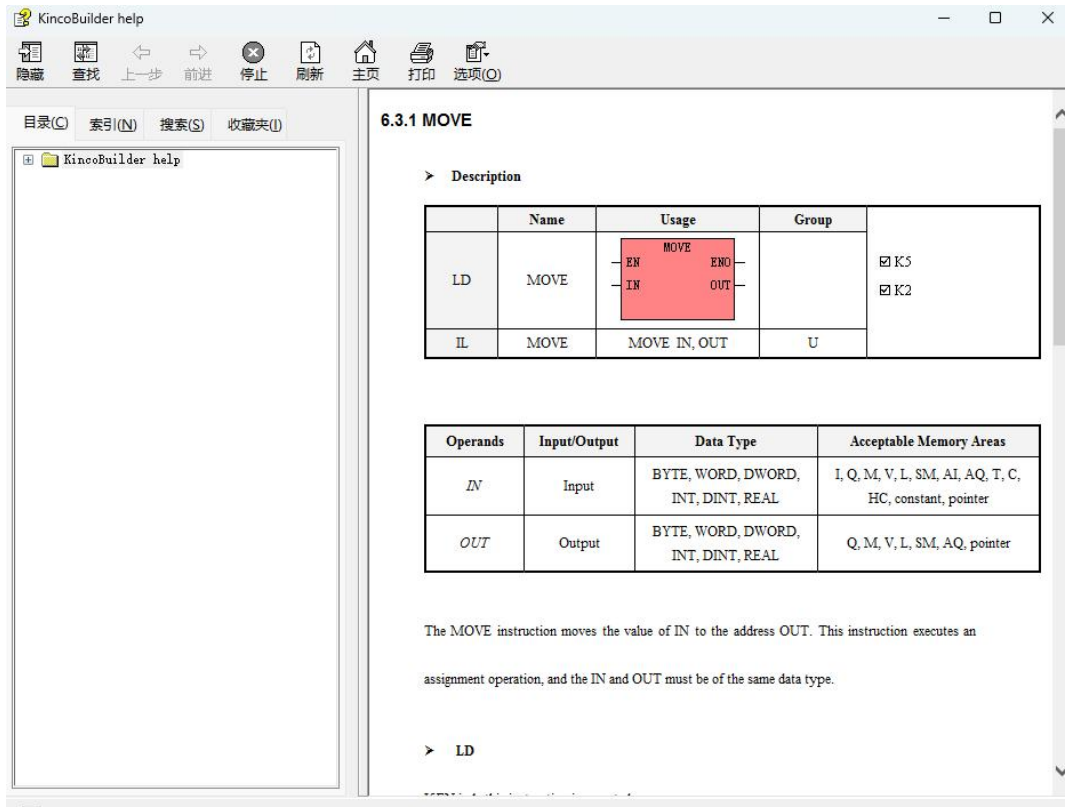

Figure 6.4-4 MOVE instruction description page

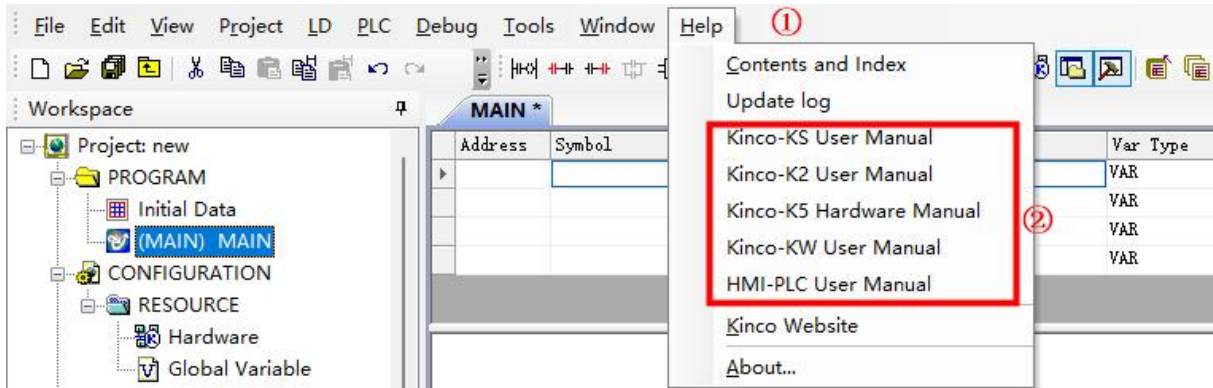

Figure 6.4-5 Software Manual in Help

② Through the software manual to find the corresponding instruction usage, please download from the official website of the step manual, the product update may lead to the software and software manual has a certain lag, please download the new version of the software and the corresponding manual from the official website in time.

(<https://www.kinco.cn/download/plc25.html>)

6.5 Compilation and simulation

6.5.1 Compilation

The PLC compiler verifies that the PLC hardware supports all program instructions, scope, and structures. All errors from the KincoBuilder compiler are listed in the output window. Double-click the error message will automatically locate to the error location. The number of generated instructions is displayed after a successful compilation. Users can click [project] [compile current project] on the toolbar, or compile the program by [compile current project] on the menu bar or directly using the F7 shortcut.



Figure 6.5-1 Compile path

6.5.2 Simulation

The offline emulator of KPLC is provided in the KincoBuilder software, which can simulate real PLC runs in KincoBuilder and debug user programs. The offline emulator of KPLC provides advanced debugging functions such as breakpoint, single-step execution, single-network execution, pause / continue operation, and serial communication emulator.

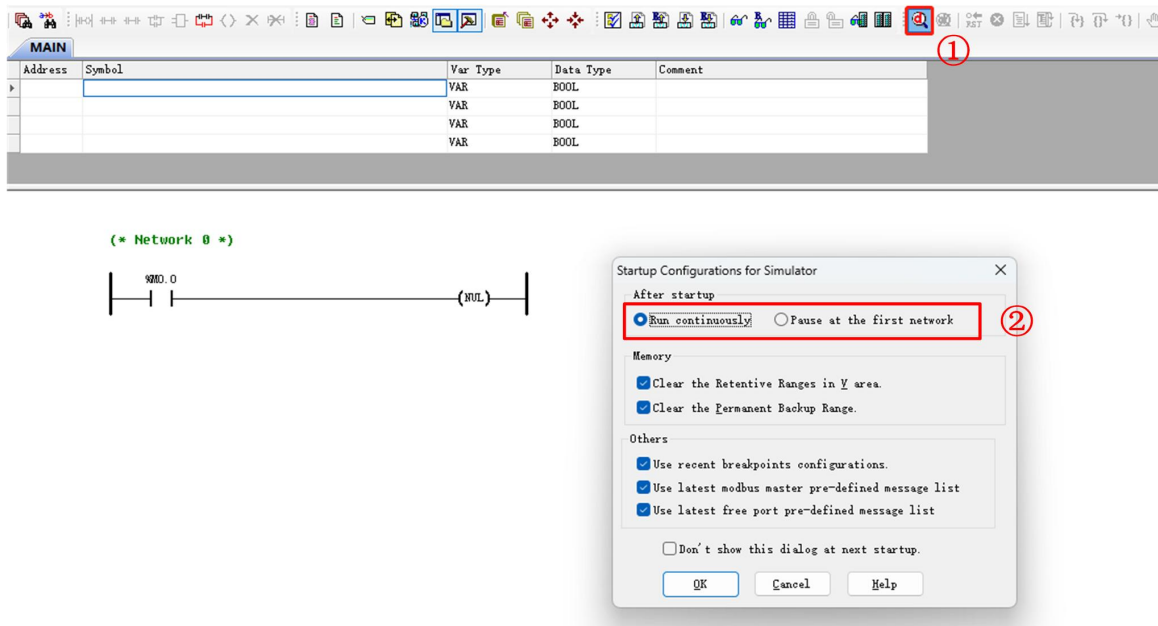

Figure 6.5-2 Simulation initiation

- Continuous operation: after the simulator is started, conduct periodic scan and execute the program;
- Pause in the first network: after the emulator is started, stop in the first scan cycle, without scanning the following program.

The K6S Series user manual

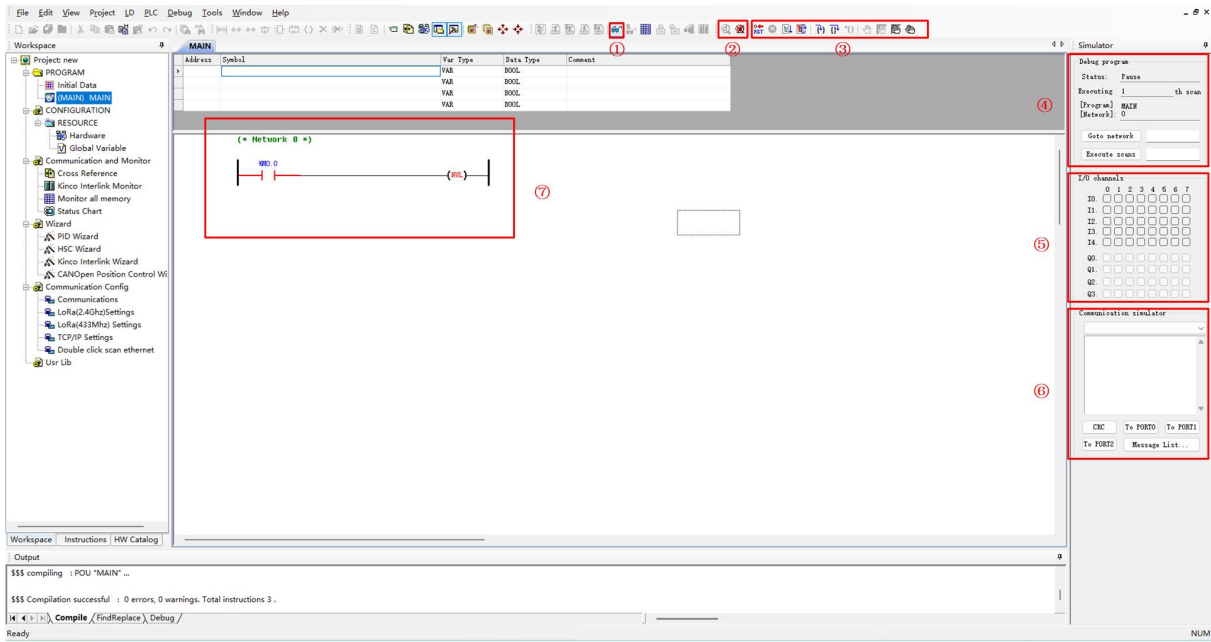















Figure 6.5-3 Simulation interface

NO.	Item	Icon/Description
①	Toggles Monitoring Mode	 :Click to enter or exit monitoring mode.
②	Enter/Exit Simulation Mode	 :Click to enter offline simulation mode.  :Click to exit offline simulation mode.
③	Function Shortcuts for Offline Debugging	 :Restart the simulation.  :Stop the program execution.  :Continual the program execution.  :adjust the scan cycle of simulation.  :Execute an instruction  :Execute a network.  :Execute to the network where cursor(line).  :Add/remove the breakpoint.  :Disable/enable the breakpoint.

		 :Disable all breakpoints.  :Enable all breakpoints.
④	Debug Program	<p>The [Debug program] window includes features such as:</p> <ul style="list-style-type: none"> • Current status display • Execution of scan cycles(executed) • Program network display(current) • Jump to the next network • Execute the specified scan cycles
⑤	I/O channels	Input or output signals can be simulated by checking the corresponding IO channel option.
⑥	Communication Simulator	Suitable for simple communication simulation debugging of XMT RCV commands.
⑦	Programming Area	This area allows the user to observe the program running and debug the program manually.

6.6 Connect and program on / download

6.6.1 PC to communicate with K615S-16DT

- The K615S-16DT communicates with the PC via the Ethernet port:
 - 1、 Use the standard network cable to correctly connect the PLC and the PC, for the PLC power on;
 - 2、 This feature supports cross-network segment scanning via [Tools] [PC Communication Settings] [Scan Network] in the upper toolbar or directly by double-clicking [Double-Click Scan Ethernet] in the left device tree. KincoBuilder Also supports modifying the IP address of the PLC scanned across network segments. Due to the function of K615S-16DT and Kincobuilder communication, only supporting communication within the same network segment, it is necessary to modify the IP address of the target PLC or the IP address of the PC to be located in the same network segment of the same LAN. Please refer to the IP of PLC according to Figure 6.6-1 or refer to Figure 4.6-2.

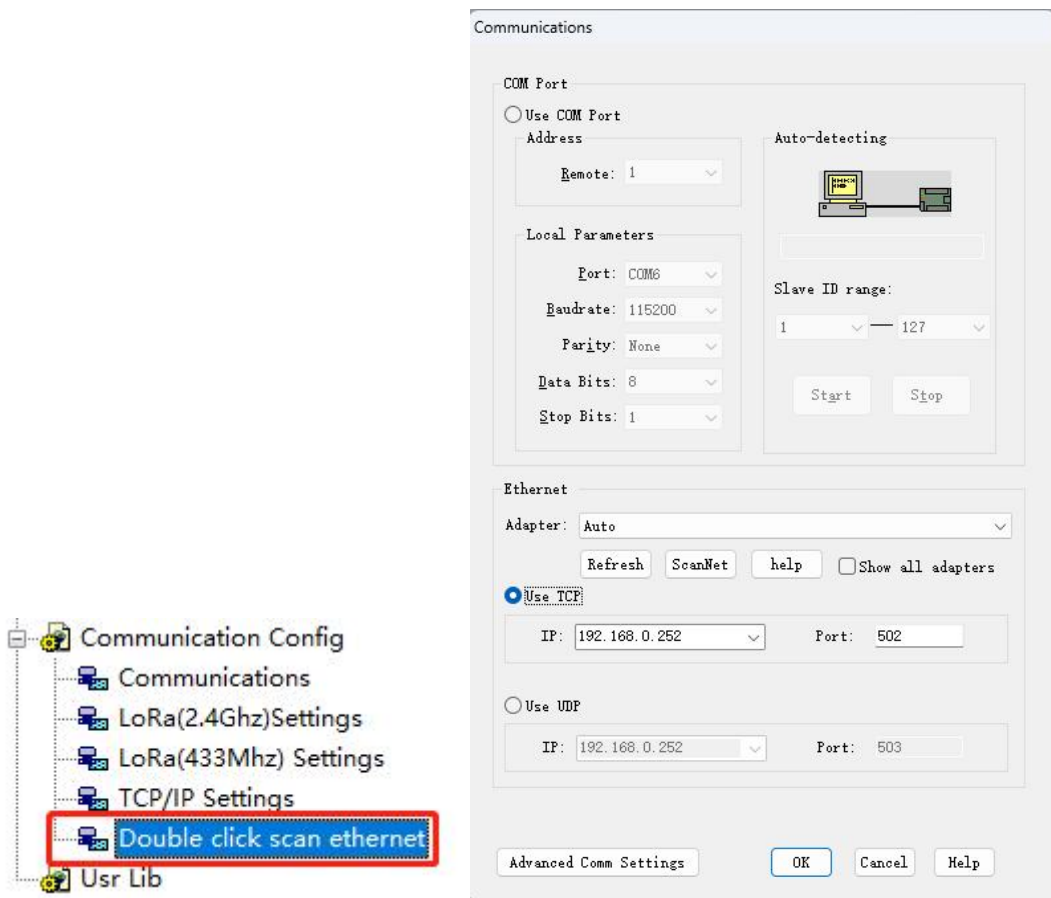

Figure 6.6-1 Scan the network

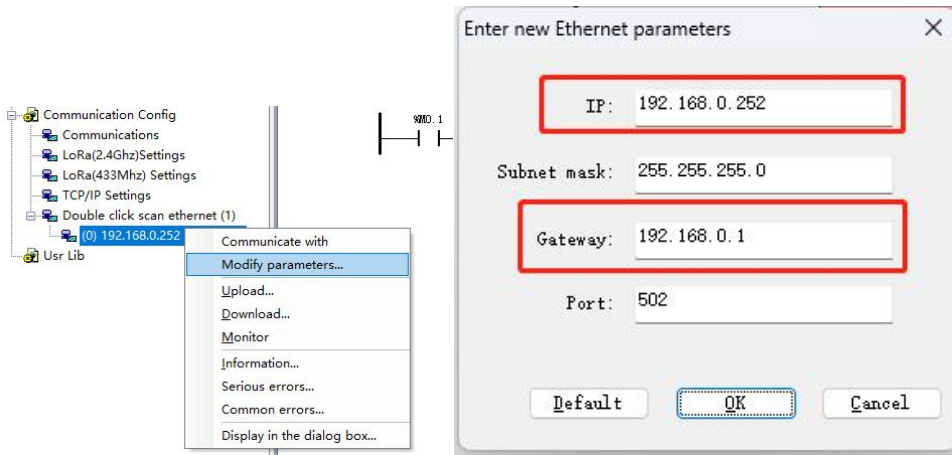

Figure 6.6-2 Modify the IP of the PLC

3、 If you cannot scan to the connected PLC, you can right-click the [Ethernet double-click Scan Ethernet] or the [PC communication settings] drop-down box of the left device tree to select the network card connected to the PLC. And then a rescan.

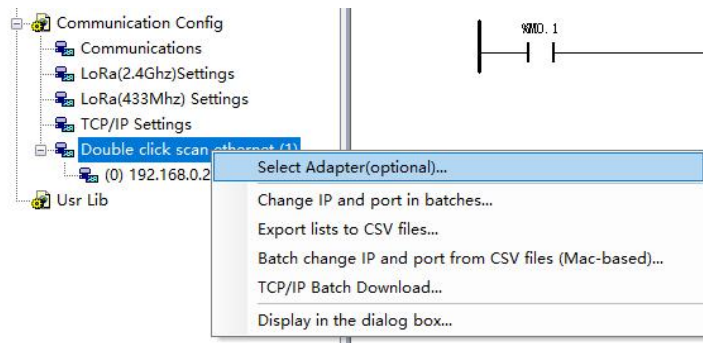

Figure 6.6-3 modify the scanning network card

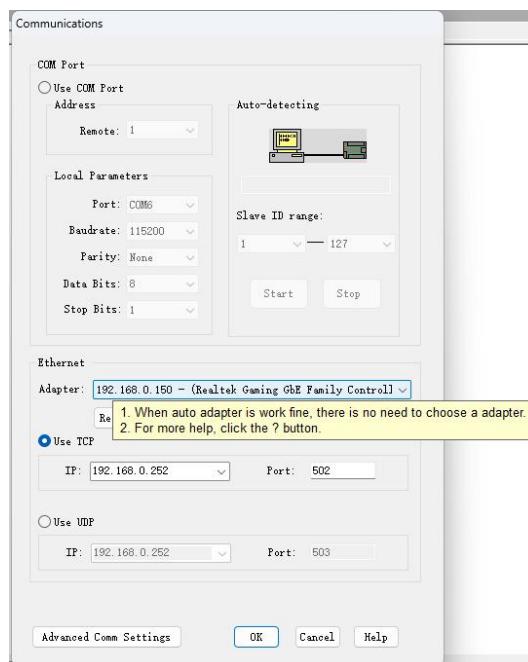

Figure 6.6-4 PC Communication Settings dialog box

4、 Regardless of the path in the above point, the corresponding PLC information will appear after a successful scan:

- [After double-click Scan Ethernet], all the PLs connected in the network appear under the device tree on the left, as shown in the left in Figure 6.6-6 below.
- The [Scan] under [PC communication settings] will pop up [Scan this LAN all PLC] popup, and all connected PLC's in the network will appear in the popup, as shown on the right of Figure 6.6-6 below.

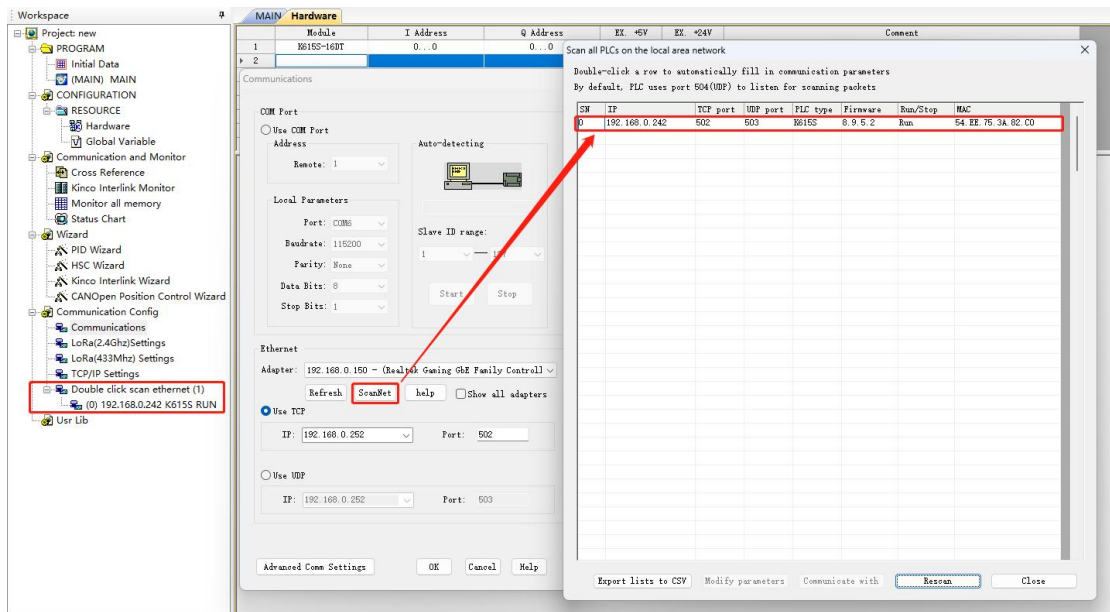
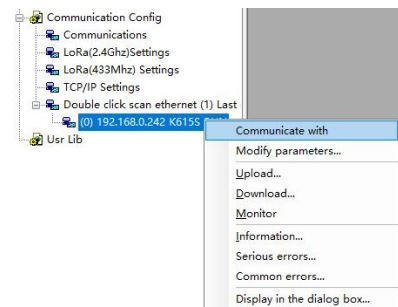

Figure 6.6-5 Scan results

5、 Right-click the scanned device found in the left device tree or right-click [scan all PLCs of the local LAN], the device in, click [communicate with this device] in the selection item, and the connection is completed without error return. If the settings in [PC Communication Settings] do not checked [Use TCP] or [Use UDP], a warning window will pop up, as shown in Figure 4.6-8 below. Through [PC pass setting], set the communication mode to [use TCP] or [use UDP] and then repeat the operation.



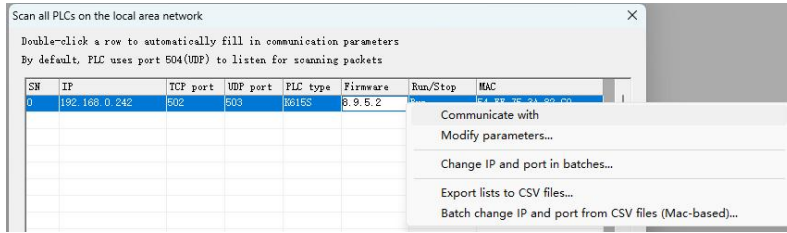

Figure 6.6-6 PLC scan and connection

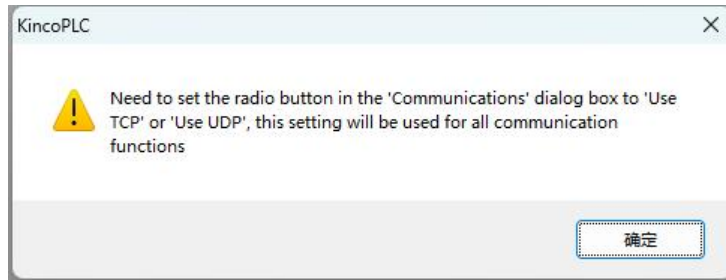

Figure 6.6-7 connection device error

- The K615S-16DT communicates with the PC via the RS485:
 - 1、 The RS485-USB programming cable is required to connect the PC and the PLC. The K615S-16DT has two RS485 interfaces, both of which support the programming protocol to power the PLC.
 - 2、 Open [Device Manager] on the PC side, find the identified COM number at [port (COM and LPT)], this example is COM3. At [PC communication setting] of KincoBuilder, select [use serial port], and change the [COM port] number to the current COM number, as shown in the figure below:



Figure 6.6-8 Serport setting of COM identification and upper computer

3、 Click [Automatic detection] to wait for the successful recognition prompt. After successful identification, the left [PC serial communication parameter] will automatically correspond to the COM parameter of the current PLC, and finally click OK to complete the connection.

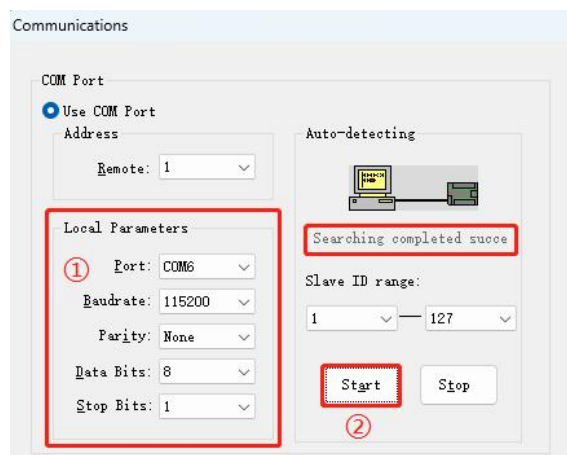

Figure 6.6-9 The COM scan

6.6.2 Program Upload / download

- KincoBuilder There are two program upload methods: [upload] and [upload (breakpoint continuation method)]. In general, the user can use [upload]. The

breakpoint continuation means that in the process of file transfer, the transmission can be restarted from the interrupted place without retransferring the entire file. This approach allows efficient file transfer even in case of network instability or interrupted transmission process. Therefore, in the case of busy network, long-distance transmission transmission and large engineering volume, it is recommended to use the upload program by [upload (breakpoint continuous transmission mode)]. Instead, [Upload] uses a one-time transmission, and if any error or interruption occurs during the transmission, KincoBuilder will directly interrupt the upload process, return the error, and require the user to retrigger the upload operation and restart the entire transmission process.

- Program upload operation process: after completing the communication connection between PC and PLC, open the upload window through the [PLC] [Upload] or [Upload (breakpoint) mode]], the upload will pop the save path selection window, click OK to select the save path, will automatically open after the upload and save the uploaded project.

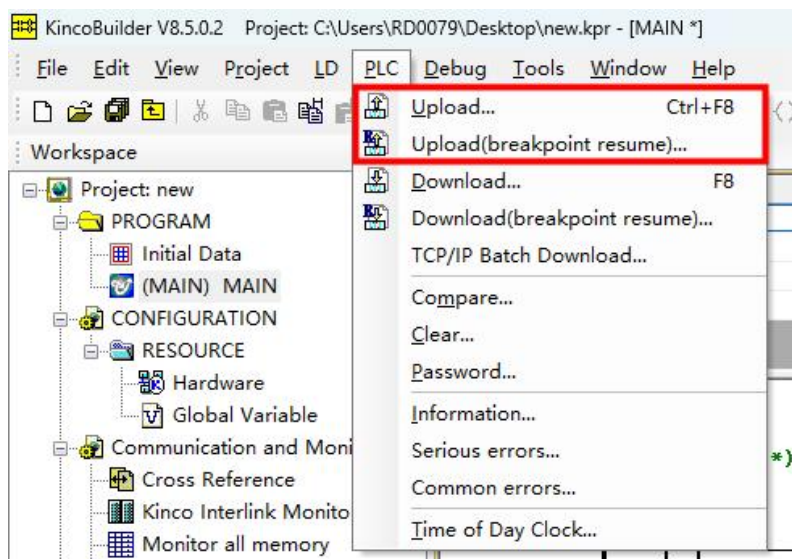

Figure 6.6-10 Program uploads the trigger path

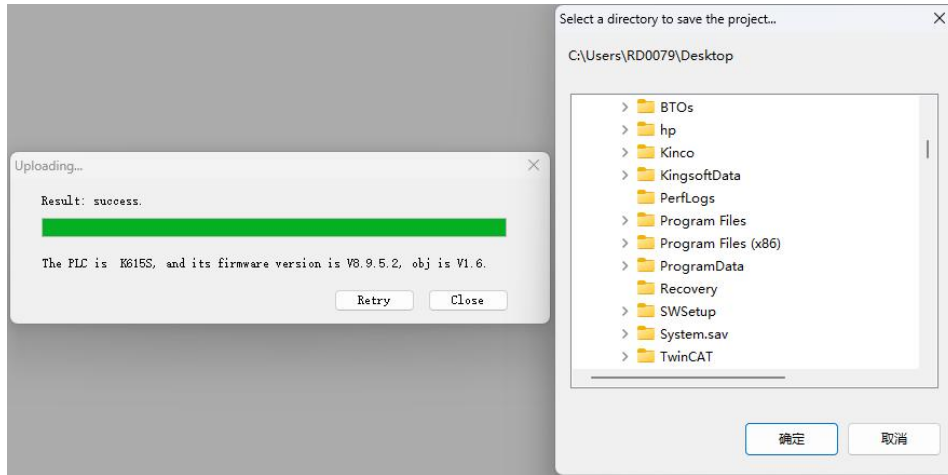

Figure 6.6-11 Upload process

- As with the program upload, KincoBuilder also offers two ways to download programs: [download] and [download (breakpoint continuation)]. Generally, users can use [download]. When the program is frequently interrupted by [download], the network is busy, long distance transmission, and the project volume is large, it is recommended to download the program by [download (breakpoint transmission)].
- Procedure upload operation process: after completing the communication connection between PC and PLC, download [PLC] [from the PLC on the menu bar...]. Or open the download window through the shortcut key [F8], the software will automatically compile the current project at the trigger, and the relevant information will be displayed in the [information output window], as shown in Figure 6.6-13 below. If the compilation passes, click [Start Download (D)], then the download process can start. After the successful download is completed, it will be prompted in the [information output window], and the software version and model of the current device will be displayed.

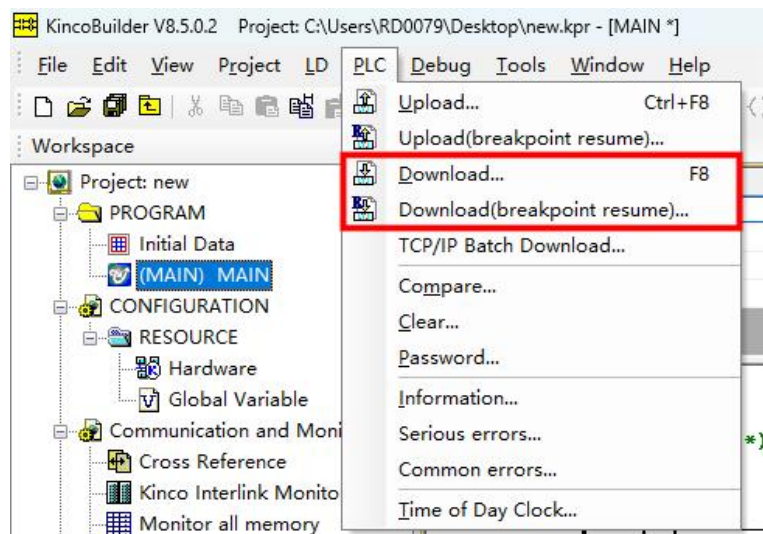

Figure 6.6-12 Download window open path

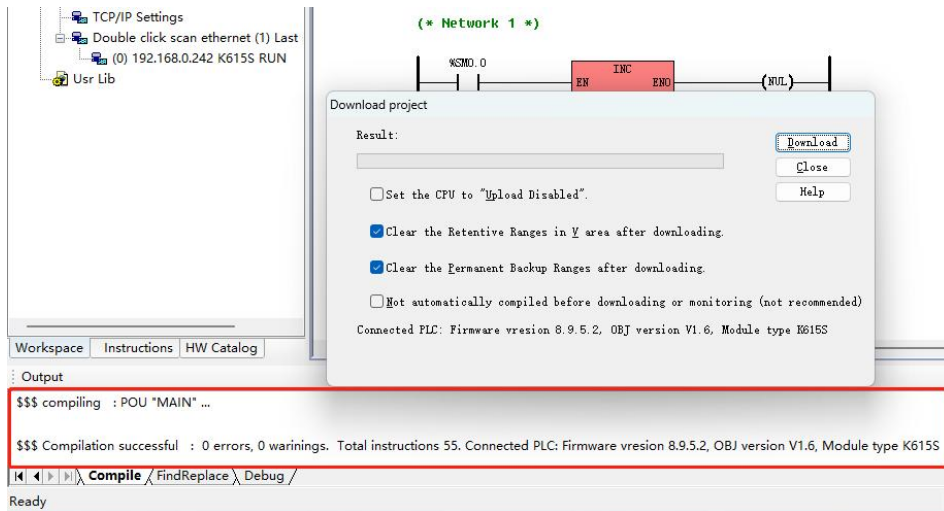

Figure 6.6-13 Auto-compiled when opened

project	description
Currently downloaded user currently currently currently user upload (U)	When this option is enabled, all PLC stored user programs are encrypted and stored in ciphertext, and the upload operation is not supported. Please check it carefully and pay attention to the program backup.
After download, the data retention zone is reset in Zone V (V)	After this option is enabled, all the data in the data holding areas V and C will be cleared after this download, and the data in areas V and C will remain unchanged after this download.
Permanent backup data area zero clearance (F) after download	When this option is enabled, all the data in the permanent data backup area will be cleared after this download. Otherwise, the data in the permanent data backup area will remain unchanged after this download.
Not automatically compiled before downloading or monitoring (not recommended) (valid before this software is closed) (N)	After this option is enabled, clicking [start download] or [online monitoring] will not automatically compile. There may be abnormal program operation or monitoring, which is not conducive to troubleshooting and monitoring of the program. Please choose carefully. This setting is only valid for opening the software after reopening the software.

6.7 Error information and processing

6.7.1 KincoBuilder Error message

The premise of viewing the error message is that the PLC and the PC are in the

communication state. If the current communication is not normal, it should be made first according to the PC communication connection method.

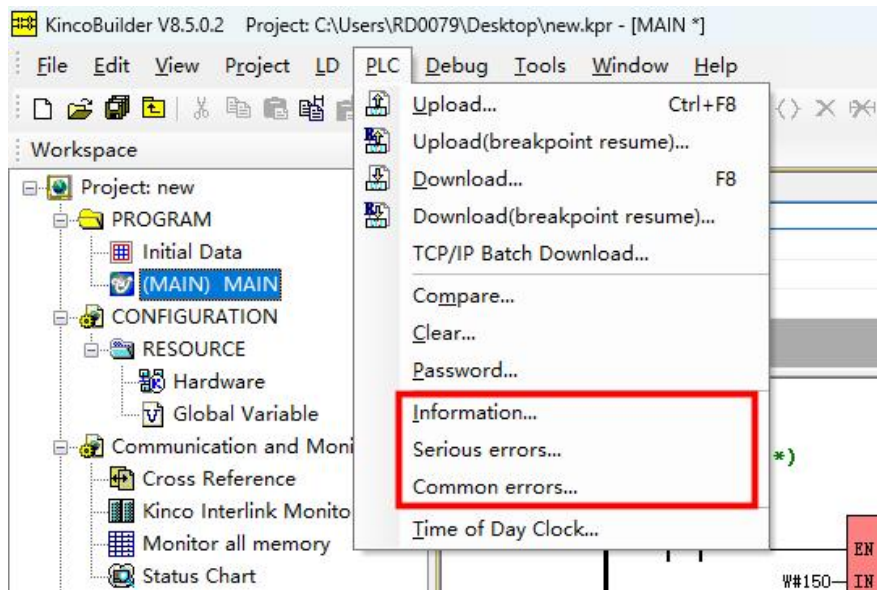

Figure 6.7-1 PLC error information query path

6.7.2 Common Error Information

Error information consists of two parts: error code and error information description. The following lists the common error code in the initial use and the corresponding solutions.

error code	error message	resolvent
20	The CPU type in Hardware Configuration does not consistent with the actual connected CPU type.	Generally, due to the actual PLC model and the PLC model configured in KincoBuilder [hardware configuration], the user can check and correct the [hardware configuration] item.
21	Ercorrect extension module in Hardware Configuration.	Prioritize whether the module addition order in [hardware configuration] is consistent with the actual connection order, and then check whether the added modules match.
29	When powered on, check for unknown instructions in the PLC program.	As the software version is updated, some instructions may be changed in KincoBuilder, such as some new instructions or functions in KincoBuilder, new instructions and functions require the latest software version and firmware version, unknown instructions are generally because the firmware version is too old to support new instructions. User should check the current software, firmware version. The updated software can be obtained on the official website

of Buke. Please contact Kinco customer support department or local service center.

[If you need more detailed error code information, open the online help or download the page on the official website \(< 1>kinco.cn/download/plc25.html\) Download \[Kinco-K series software manual\] query solution.](http://kinco.cn/download/plc25.html)

6.8 Firmware update

KincoBuilder With the firmware update program in the software, users can update the PLC to the PLC on the software, and the detailed steps to open the firmware update program are as follows: Toolbar [tool] [Update system program (general version)...].

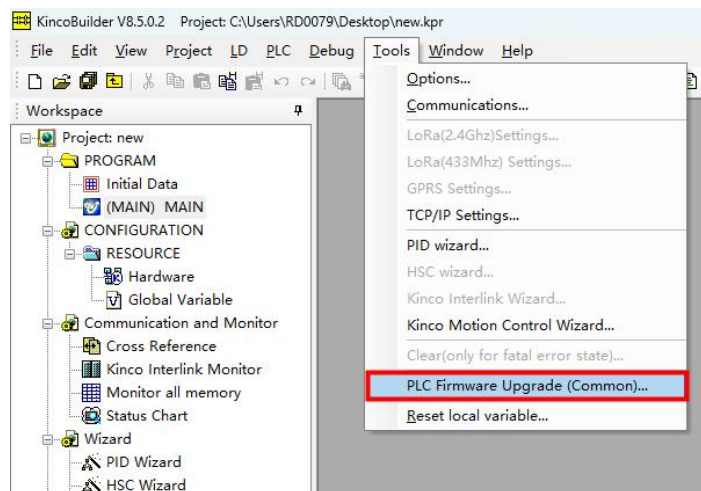

Figure 6.8-1 Program update trigger operation

After opening the firmware update program, the program update operation prompt page will pop up, as shown in the following figure:

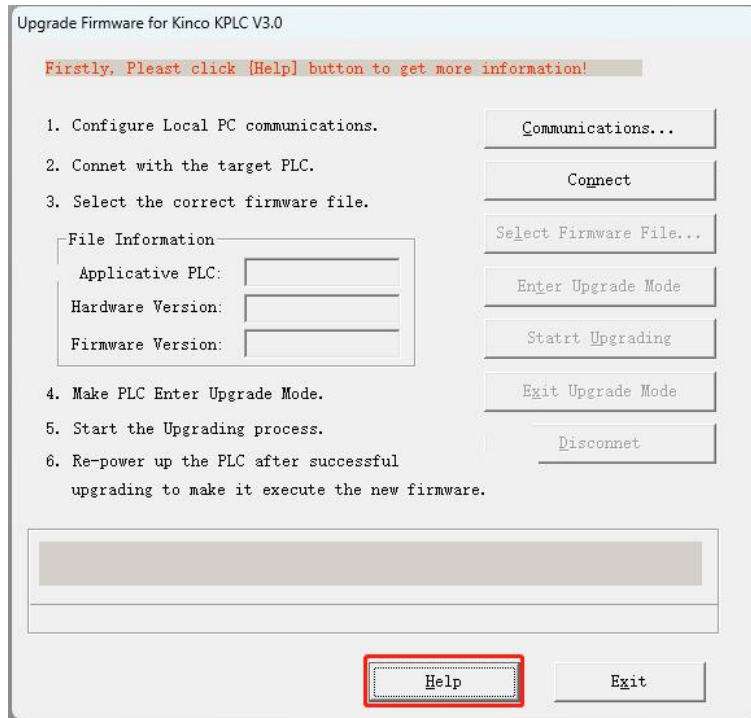

Figure 6.8-2, the program update interface

Due to the differences between PLC products, the method to enter the system update mode also varies. Before starting the firmware update, read the [Help] document in the [KPLC Update System Program] interface carefully. The specific update steps have been written in detail on the left side of the update program interface. The user can operate according to the instructions of the corresponding model.

Here is the applicable firmware update method for K6S series. The update steps are as

1. Use the communication cable to connect the PLC to the computer, and then power up the PLC.

Note: Products with USB interface support direct power supply by USB cable, with no external power supply when updating.

2. Click the [Set PC communication parameters] button to enter the configuration window to configure the communication parameters of the PC.

pour:

- If you use a USB port to update, you do not need to modify the communication parameters because it is a virtual serial port.
- If the serial port is used, note that the port rate 115200, no check, 8 bit data bit, 1 bit stop, please first change the communication parameters of the corresponding PORT in the user project [hardware configuration] to the above configuration, and then download the new project to the PLC, the new parameters will take effect immediately after the PLC is successfully run.

follows:

Update failed resolution:

If the user encounters an error prompt that the update failed during the update, and the PLC running indicator [RUN] is constantly flashing, the user can try to start repeatedly [start update the system program].

If the user powers up after the update fails, he can connect the module but cannot enter the target update mode. You can power off the device for a period of time before performing the firmware update operation.

If the firmware update operation is still impossible, ask the user to check the [RUN] light flashing, battery power and firmware version and contact the step section technical support or local agency for help.

7. Product and service support

7.1 Product Support

- **Technical service hotline**

If you have any questions about the product selection or use process, you can call our technical service hotline for technical support service: 400-700-5281.

- **Agents and offices**

If you have any questions about the products described in this manual, please contact our company office and agent. For user training and other information, please log on the company website for relevant content, or directly contact the local agent for the training plan.

7.2 Contact us

Shanghai Buke Automation Co., Ltd

Address: Building 3, No.26, Qiuyue Road, Zhangjiang High-tech Park, Shanghai (201203)

Tel.: 86-21-68798588

Fax: 86-21-68797688

Email: salse@kinco.cn

Shenzhen Buke Automation Co., Ltd

Address: 3 F, Building 1, Yizhong Industrial Park, No.6, Langshan First Road, North District, High-tech Park, Nanshan District, Shenzhen (518057)

Tel: 86-755-26585555 (12 line)

Fax: 86-755-26616372

Email: salse@kinco.cn

8 Appendix

8.1 Quick selection list

model	description
CPU module	
K615S-16DT	<p>DC 24V Power supply;</p> <p>DI 8*DC 24V(PNP/NPN), DO 8*DC 24V(PNP);</p> <p>Support 3-road 200 KHz high-speed count input, 1 single phase 20 KHz / double phase 10 KHz;</p> <p>Support 3200 KHz high speed pulse output, 1 maximum 10 KHz high speed pulse;</p> <p>Integrated communication interface: 2 * RS485,1 * Ethernet, 1 * CAN;</p> <p>Up to the maximum support for 16 K6S module expansion;</p>
Expand the module	
K621S-16DX	DI 16*DC 24V(NPN/PNP);
K622S-16DR	DO 16 * relay;
K622S-16DT	DO 16*DC 24V(PNP);
K623S-16DT	DI 8*DC 24V(NPN/PNP), DO 8*DC 24V(PNP);
K622S-16DTN	DO 16DC 24V (NPN)
K633S-06IV	<p>12-bit resolution with a precision of 0.3% F.S.;</p> <p>AI*4: 4-20mA、1-5V、0-20mA 、0-10V ;</p> <p>AO*2: 4-20mA 、1-5V、0-20mA、0-10V ;</p>
K631S-04TC	<p>4-channel thermocouple input;</p> <p>Support for types J, K, E, S, T, thermocouples,</p> <p>Cold end internal compensation and external compensation are optional;</p> <p>24-bit resolution; precision 0.1% F.S.;</p>
K631S-04RD	<p>4-channel thermal resistance input, support Pt 100, Cu 50, Pt1000 resistance form;</p> <p>Support the two-wire system, three-wire system wiring mode; 24-bit resolution;</p> <p>Temperature: $\pm 0.6^{\circ}\text{C}$; resistance: $\pm 1 \Omega$;</p>